

Installation, Operation  
and Maintenance  
Instructions for

# Mighty Therm

Volume Water Heaters

Model VW-PW

Sizes 175-400

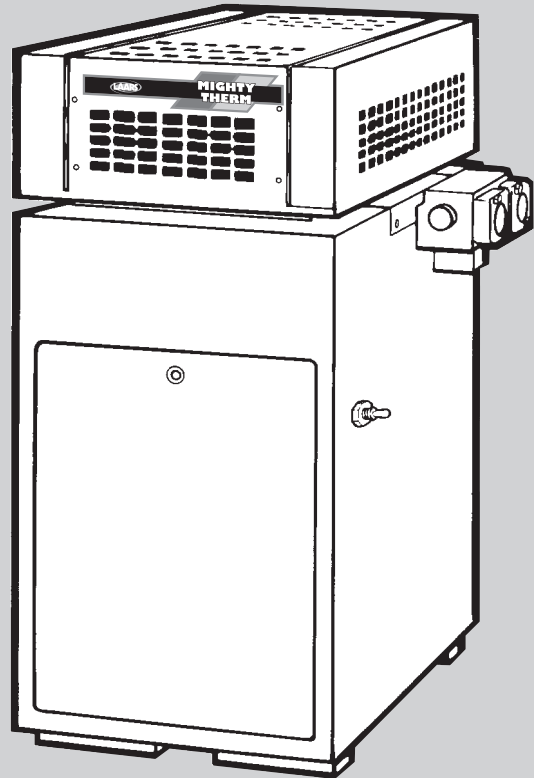

**FOR YOUR SAFETY:** This product must be installed and serviced by a professional service technician, qualified in hot water heater installation and maintenance. Improper installation and/or operation could create carbon monoxide gas in flue gases which could cause serious injury, property damage, or death. Improper installation and/or operation will void the warranty.

## **⚠ WARNING**

If the information in this manual is not followed exactly, a fire or explosion may result causing property damage, personal injury or loss of life.

Do not store or use gasoline or other flammable vapors and liquids in the vicinity of this or any other appliance.

### WHAT TO DO IF YOU SMELL GAS

- Do not try to light any appliance.
- Do not touch any electrical switch; do not use any phone in your building.
- Immediately call your gas supplier from a nearby phone. Follow the gas supplier's instructions.
- If you cannot reach your gas supplier, call the fire department.

Installation and service must be performed by a qualified installer, service agency, or gas supplier.

## TABLE OF CONTENTS

### SECTION 1.

#### General Information

1A.	Introduction .....	3
1B.	Warranty .....	3
1C.	Technical Assistance .....	3

### SECTION 2.

#### Installation Instructions

2A.	General Information .....	4
2B.	Field Assembly .....	4
2C.	Site Location .....	5
2C-1.	Installation Information .....	5
2C-2.	Outdoor Installation (U.S. only) .....	5
2C-3.	Flooring - Typical Installation .....	6
2D.	Combustion and Ventilation Air Supply .....	6
2D-1.	Outdoor Air Supply .....	7
2D-2.	Indoor Air Supply .....	7
2D-3.	Exhaust Fans or Vents .....	7
2E.	Venting of Combustion Products .....	7
2E-1.	General Information .....	7
2E-2.	Replacement of Existing Heater .....	8
2F.	Water Flow .....	8
2F-1.	Reversible Water Connections .....	8
2F-2.	Water Chemistry .....	11
2F-3.	Freeze Protection .....	11
2F-4.	Water Hardness .....	11
2F-5.	Pump Requirements .....	11
2F-6.	Pressure Buildup in Water System .....	11
2F-7.	Pressure Relief Valve .....	14
2F-8.	Water Pressure .....	14
2F-9.	Pump Installation .....	14
2F-10.	Storage Tank Installation .....	14
2F-11.	Thermal Circulation of Hot Water in Cold Water Supply Lines .....	15
2G.	Gas Supply and Piping .....	15
2G-1.	General Instructions .....	15
2G-2.	Special Precautions for Propane Gas .....	16
2H.	Electrical Wiring .....	16
2I.	Combined Space Heating/Potable Water Heating Systems .....	16
2I-1.	Combined Space Heating .....	16
2I-2.	Potable Water Heating .....	16

### SECTION 3.

#### Operating Instructions

3A.	Normal Operating Sequence .....	17
3B.	Start-Up Procedure .....	17
3C.	Setting the Temperature Controls .....	17
3D.	Adjustment for Minimum Input Rate (models with modulating gas valve) .....	20
3E.	Hi-Limit Switch Checkout .....	20
3F.	Shut-Down Procedure .....	20

### SECTION 4.

#### Maintenance

4A.	General Instructions .....	20
4B.	Replacement of Gas Controls .....	21
4C.	Heat Exchanger .....	22
4C-1.	Inspecting the Heat Exchanger .....	22
4C-2.	Cleaning the Heat Exchanger .....	23

### SECTION 5.

#### Troubleshooting

5A.	Gas Pressure Tests .....	23
5A-1.	Checking the Main Line Gas Pressure .....	23
5A-2.	Checking the Manifold Regulated Gas Pressure .....	24
5B.	Electrical Troubleshooting .....	24
5B-1.	Heater Does Not Come On .....	24
5B-2.	Testing the Transformer .....	25
5B-3.	Testing the Electrical Power Supply .....	25
5B-4.	Testing the Manual Reset Hi-Limit Switch .....	25
5B-5.	Testing the Flow Switch .....	25
5B-6.	Testing the Fusible Link (Flame roll-out switch) .....	26
5B-7.	Testing the Fuse .....	26
5B-8.	Testing the Ignition Control (for spark ignition) .....	26
5B-9.	Testing the Ignition Control (for standing pilot) .....	27
5B-10.	Testing the High Voltage Ignition Lead .....	27
5B-11.	Testing the Safety Shutoff (for standing pilot) .....	28
5B-12.	Testing the Safety Shutoff (for automatic pilot) .....	28
5B-13.	Testing the Igniter Electrode .....	28
5B-14.	Testing the Pilot Thermocouple (for standing pilot) .....	28
5B-15.	Testing for Pilot burner (for spark ignition) .....	28
5B-16.	Testing for Burner Ignition (for standing pilot) .....	29
5B-17.	Heater Will Not Shut Off .....	29
5B-18.	On-Off Main Burner Cycling .....	29
5B-19.	Testing the Terminal Strip/External Controls .....	29

### SECTION 6.

#### Parts List

6A.	General Information .....	30
6B.	Parts List .....	30

## SECTION 1. General Information

### 1A. Introduction

This manual provides installation, operating, and maintenance instructions for Models VW and PW Volume Water Heaters, Sizes 175 through 400. Review all application and installation procedures completely before proceeding with the installation. Experience has shown that most operating problems are caused by improper installation.

The VW-PW heaters are offered in a basic configuration (see Figure 1). On PW heaters the pump is factory installed. On VW heaters the pump is field installed.

### 1B. Warranty

The VW-PW heaters are sold with a limited factory warranty.

Make all warranty claims to an authorized Laars representative or directly to the factory. Claims must

include the heater serial number and model (this information can be found on the rating plate), installation date, and name of the installer. Shipping costs are not included in the warranty coverage.

Some accessory items are shipped in separate packages. Inspect everything for damage immediately upon delivery, and advise the transporter of any shortages or damage. Any such claims should be filed with the transporter. The transporter will not accept a claim from the shipper, Laars.

The warranty does not cover damage caused by improper installation, operation, or field modification.

### 1C. Technical Assistance

Consult Laars or your local wholesaler with any questions or problems involving the specification, installation and operation of Laars equipment. An experienced technical support staff is ready to assist in assuring the proper performance and application of Laars products.

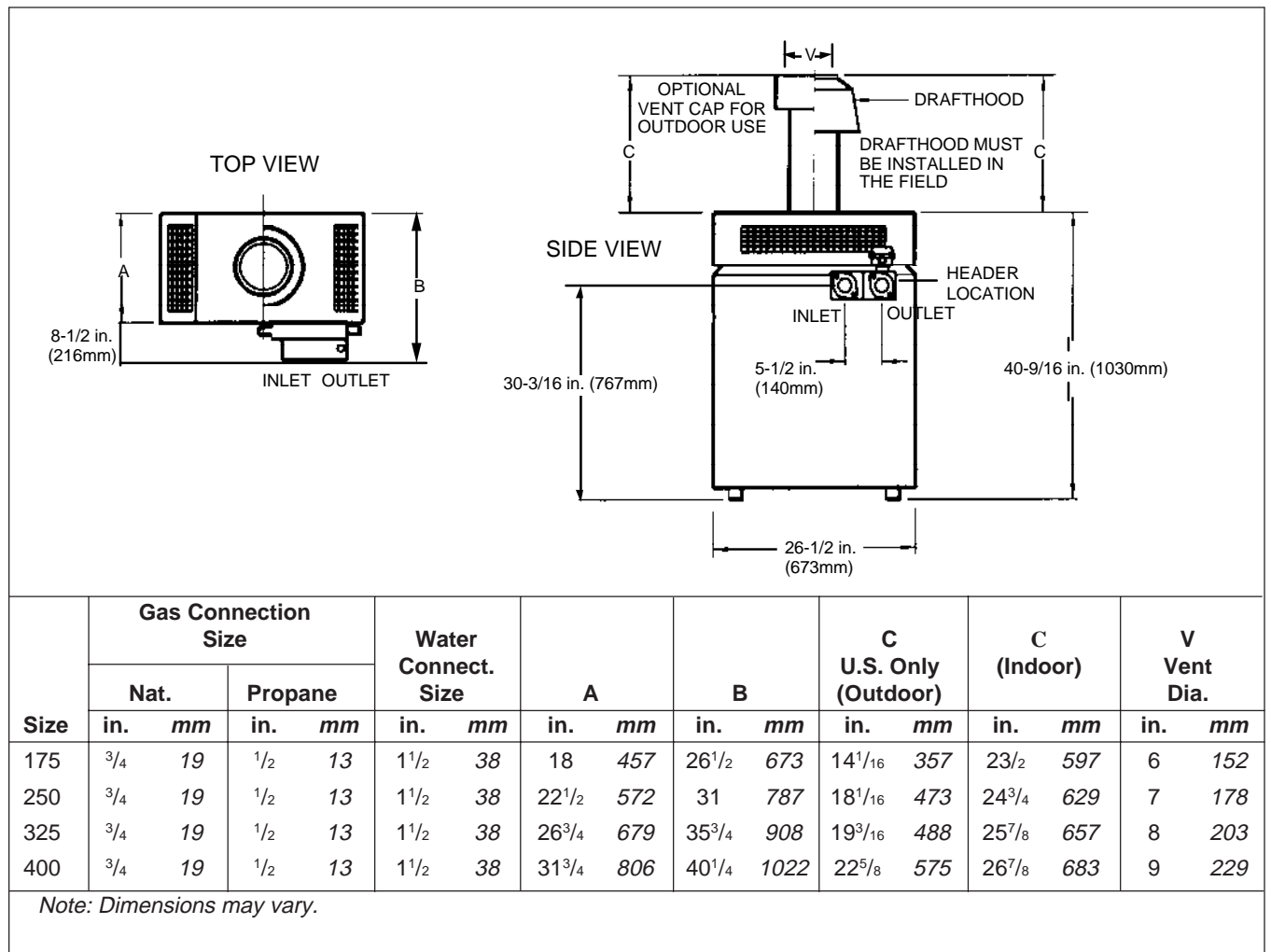

Figure 1. General configuration.

## SECTION 2. Installation Instructions

### 2A. General Information

#### **⚠ WARNING**

Follow local regulations with respect to installation of carbon monoxide (CO) detectors and manufacturer's maintenance schedule of the heater.

Install the VW-PW heaters in accordance with the procedures in this manual (or the Laars warranty may be voided), local codes and ordinances. In the absence of such codes, install the heaters in accordance with the latest edition of the National Fuel Gas Code, ANSI Z223.1. In Canada, the installation must be in accordance with CAN1-B149.1 or .2 and local codes. The authority having jurisdiction may require the installation conform to the Standard for Controls and Safety Devices for Automatically Fired Heaters, ANSI/ASME CSD-1. Any changes to the heater, gas controls, gas orifices, wiring or draft diverter may void the warranty. If field conditions require a change to any of the above, consult the factory.

All gas-fired products require correct installation to assure safe operation. The requirements for heaters include the following:

1. Field assembly of draft hood or vent cap (see Section 2B).
2. Appropriate site location (clearances) and flooring.
3. Sufficient combustion and ventilation air.
4. Adequate venting of combustion products.
5. Adequate water flow.
6. Properly sized gas meter and piping.
7. Proper electrical wiring.

This manual provides the information needed to meet these requirements. Review all application and installation procedures completely before continuing the installation.

### 2B. Field Assembly

The VW-PW heater is shipped from the factory with the top assembly in the low-profile configuration for outdoor installations.

The VW-PW heater is design certified for indoor installation when equipped with a special draft hood, which must be installed without modification. The part

number for the draft hood is on the heater rating plate. Follow this procedure to make the conversion:

- a. Remove the top filler plate, stamped "HOT", by slipping a fine-blade screwdriver into the slot at the rear of the plate and gently prying it up (see Figure 2).
- b. Remove the two screws attaching the adapter plate to the top assembly and lift it out (see Figure 3).
- c. Remove the vent cap or draft hood from its package.



Figure 2. Top filler plate.

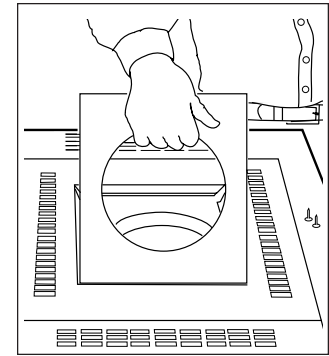

Figure 3. Adapter plate.

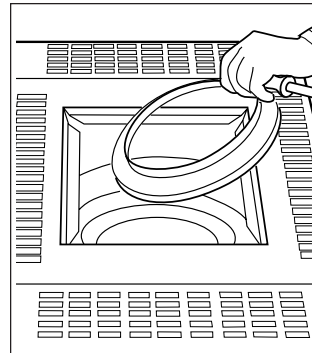

Figure 4. Flue transition ring.

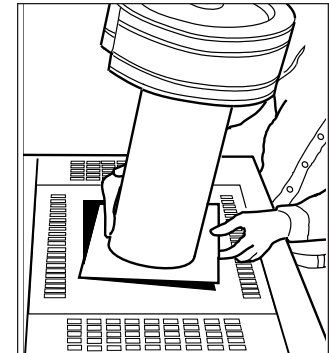

Figure 5. Vent cap with adapter plate (outdoor).

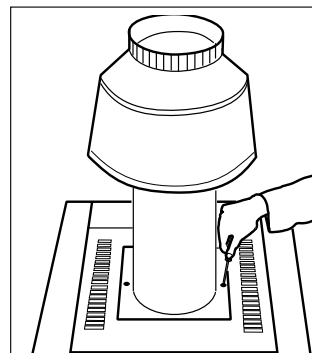

Figure 6. Draft hood with adapter plate (indoor).

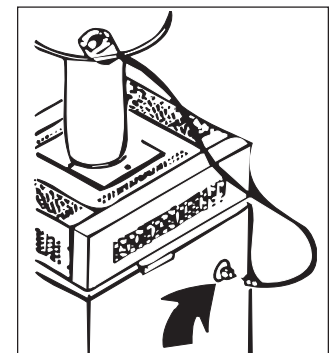

Figure 7. Draft hood switch receptacle.

- d. Disengage the flue transition ring from the stack extension and place it on top of the collector assembly as shown in Figure 4.
- e. Slide the adapter plate over the bottom of the stack extension as shown in Figure 5. Fit the stack extension down over the flue transition ring. Seat the adapter plate on the top assembly and secure it with two screws (see Figure 6).
- f. Indoor models, size 175 and 250 only, require an adapter cable (included with product). The cable connects the blocked vent safety switch (BVSS) on the bell of the external draft hood to the 6-position Molex plug on the side of the unit (see Figure 7). Refer to instruction sheet included with cable.

## 2C. Site Location

### 2C-1. Installation Information

**⚠ WARNING**

Improper installation or maintenance can cause nausea or asphyxiation from carbon monoxide in flue gases which could result in severe injury, property damage, or death.

Avoid placing the heater in locations where it can be damaged by water or condensate leakage. If this is not possible, provide a suitable drain pan to catch and divert any leakage. The pan must not block natural flow of air around the heater.

Locate the heater to provide adequate clearance on all sides for inspection, service and to provide adequate air circulation for proper operation.

Locate the heater so the clearances from combustible surfaces shown in Table 1 and Figure 8 are met.

Clearance from:	Indoors		Outdoors	
	inch	mm	inch	mm
Top	37	940	Unobstructed	
Water conn. side	12	305	Unobstructed	
Opposite side	6	152	6	152
Front	Alcove		Unobstructed	
Rear	6	152	6	152
Vent*	6	152	—	
Flooring	Combustible		Combustible	

Service clearance = 36 inches (914mm) at front of heater, and 18 inches (457mm) at water connection side.  
 \*1" (25mm) if double wall vent is used.

**Table 1. Minimum Boiler Clearances from Combustible Surfaces.**

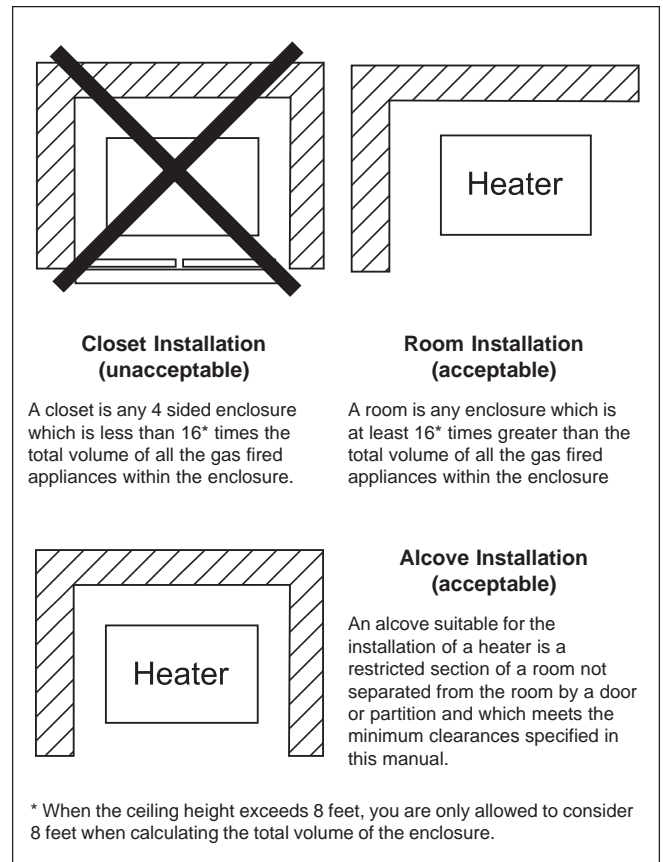

**Figure 8. Alcove installation.**

Locate the heater on a waterproof floor with a floor drain and a 6 inch (152 mm) minimum curb on all four sides to protect the building if heater repairs are needed.

### 2C-2. Outdoor Installation (U.S. Only)

**⚠ Caution**

Outdoor installations are not recommended in areas where the danger of snow blockage exists. VW-PW heaters can be installed in the standard low-profile, grate top configuration as received from the factory, or with an optional vent cap.

Locate the heater in an open, unroofed area. Do not locate the heater below or adjacent to any doors, windows, louvers, grills, etc., which connect in any way with an inhabited area of a building, even though the access might be through another structure such as a garage or utility room (see Figure 9 and Table 1). There must be a minimum of 4 feet (1.22 m) horizontally and vertically between the heater and any door, window, or gravity inlet to a building (see Figure 10).

If the heater is installed close to a structure, protect it from rain water runoff with rain gutters on the roof or other measures. Do not locate the heater near sprinkler systems that could spray water on it.

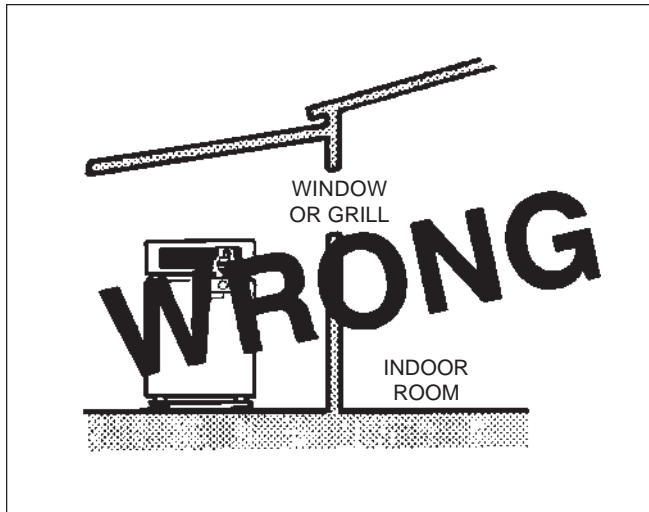

Figure 9. Incorrect outdoor installation.

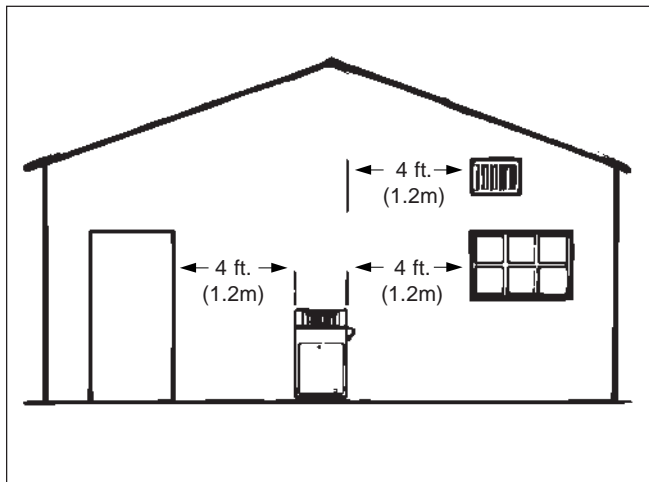

Figure 10. Outdoor location installation.

Avoid locations where wind deflection off nearby structures might cause wind loading and downdraft conditions. Where downdraft conditions exist, locate the heater at least 3 feet (0.91 m) from the structure.

**2C-3. Flooring - Typical Installation**

**Do not** install the heater directly on carpeting without placing a non-combustible platform between the carpeting and the heater. If the heater is installed in a carpeted alcove, the entire floor of the alcove must be covered by a non-combustible panel. The panel must be strong enough to carry the total weight of the heater and all piping, pumps, and any other equipment attached to the heater. For rooftop installation, see Figure 11 through Figure 13.

**2D. Combustion and Ventilation**

**Air Supply**

All indoor installations must have openings to outside air for combustion, ventilation and dilution of

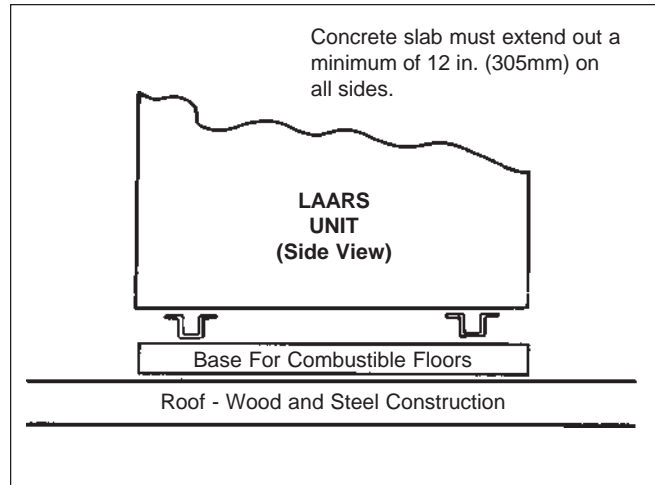

Figure 11. Standard base for combustable floor.

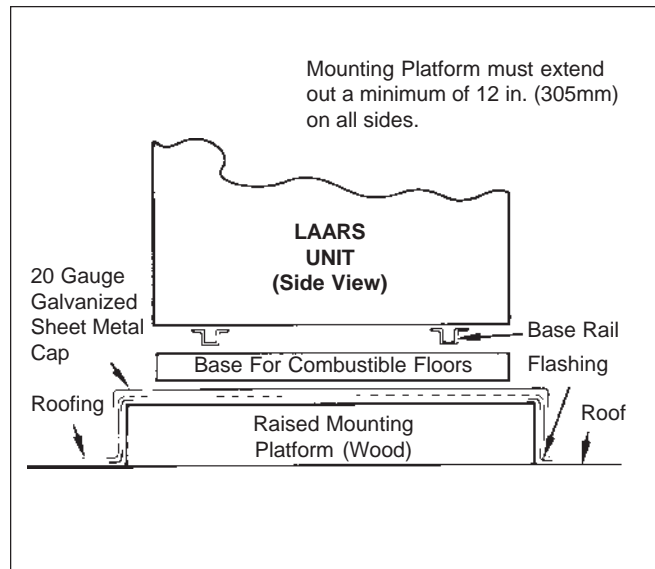

Figure 12. Typical roof mounting.

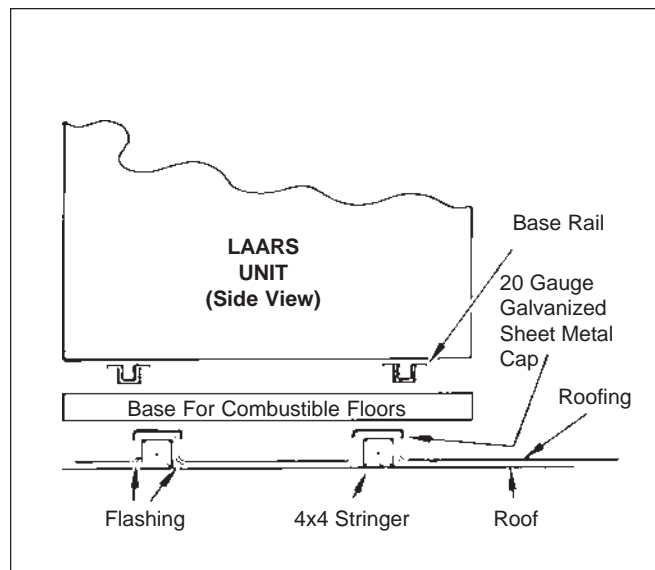
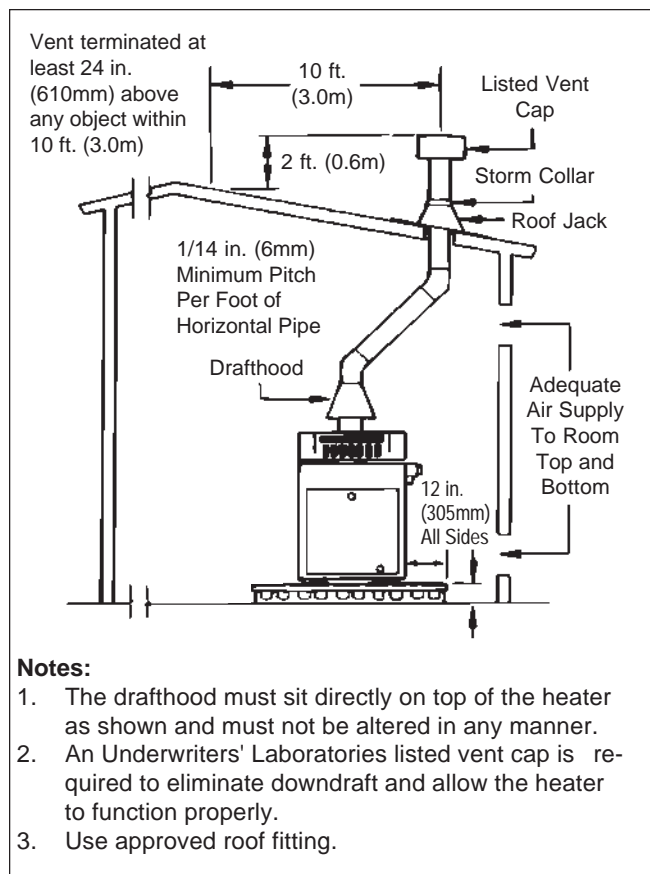

Figure 13. Typical roof mounting with standard combustable mount base.

Model	Required Net Free Opening Area Directly from Outside			
	At Top		At Bottom	
	in. <sup>2</sup>	cm <sup>2</sup>	in. <sup>2</sup>	cm <sup>2</sup>
175	44	284	44	284
250	63	406	63	406
325	82	529	82	529
400	100	645	100	645

**Note:** For screens or louvers, add 50%.

**Table 2. Air Openings to Outside.**



**Figure 14. Indoor installation and venting.**

flue gases from inside the building (see Figure 14 and Table 2 ). Laars does not recommend indoor installations that do not provide combustion air from outside the building.

Heater rooms which are confined spaces require two permanent air supply openings: one within 12 inches (305 mm) of the ceiling, the other within 12 inches (305 mm) of the floor.

**NOTE:** Check with louver manufacturers for net free area of louvers. If screens or louvers are installed, add 50 percent for each screen/louver to the net free area Check all local codes applicable to combustion air.

**2D-1. Outdoor Air Supply**

When combustion air comes directly through an outside wall, each opening must have a minimum free area of at least one square inch for each 4,000 BTU/h input of the total input rating of all appliances in the enclosed area. (In Canada, refer to CGAB149.1 and .2.)

**2D-2. Indoor Air Supply**

Confined and non-confined areas have different requirements for installation. Consult the latest edition of the National Gas Code for installation requirements.

**2D-3. Exhaust Fans or Vents**

Any equipment which uses air or removes air from the heater room can use up the combustion air supply or reverse the natural draft action of the venting system. This could cause flue products to build up in the heater room. More air must be supplied to make up for the decrease.

**2E. Venting of Combustion Products**

**2E-1. General Information**

When installed indoors, the draft hood must be connected to a venting system. The venting system must be installed by a qualified installer and in accordance with the latest edition of ANSI Z223.1. In Canada, the installation must be in accordance with CAN1-B149.1 or .2, and any local codes that apply.

The vent pipe must have a listed vent cap, and extend at least 2 feet (0.6 m) above any object within a 10 foot (3.0 m) radius.

**NOTE:** Do not use sheet metal screws at the snap lock joints of Type B double-wall gas vents.

Do not weld or bolt the vent pipe to the heater draft hood. The weight of the stack must not rest on the heater. The draft hood and heater top must be easily removable for normal heater service and inspection.

**⚠ WARNING**

Avoid ending heater vents near air conditioning or air supply fans. The fans can pick up exhaust flue products from the heater and return them inside the building, creating a possible health hazard.

Avoid horizontal runs of the vent pipe and 90 degree elbows, reductions, and restrictions. Horizontal runs should have at least a 1/4 inch (6.3 mm) rise per foot in the direction of flow. Support a vent connector for the design and weight of the material used to maintain clearances and physical damage and separate of joints.

Always use double-wall or insulated vent pipe (Type B or equivalent).

### WARNING

In cold weather, uninsulated outside vents can chill the rising flue products, blocking the natural draft action of the venting system. This can create a health hazard by spilling flue products into the heater room.

Avoid oversized vent piping or extremely long runs of the pipe which may cause too much cooling and condensation of flue gasses.

When the installation of a power vent or draft fan in the venting system is necessary, qualified personnel should design the installation following good engineering practices and all applicable codes. A suitable draft switch must be wired into the heater control circuit at the terminal designated Field Interlock to keep the heater from firing unless there is a positive draft.

#### 2E-2. Replacement of Existing Heater

When a heater is removed from a common venting system, the venting system may be too large for proper venting of the other appliances connected to it.

If replacing an existing heater with a VW or PW heater and the existing heater was connected to a common venting system, the common venting system must comply with ANSI Z223.1/National Fire Protection Association (NFPA) 54. When resizing any portion of the common venting system, the common venting system should be resized to approach the minimum size as determined using the tables in ANSI Z223.1/NFPA 54, Appendix G. In Canada, the common venting system should be resized so the installation will be in accordance with CAN/CGA B149.1 or .2.

## 2F. Water Flow

### 2F-1. Reversible Water Connections

**NOTE:** This procedure is not recommended for the PW pump-mounted models.

Laars ships the VW heater with the water connections on the right side. The VW heater can be installed with the water connections on either side. It could be necessary, or helpful, to switch the connections to the left side to improve access for installation service. Have a professional service technician perform this modification before installing the heater using the following procedures:

1. Remove the front cover.
2. If there is a vent cap or draft hood installed, they must be removed before removing the grate top

assembly. On indoor installations (sizes 175-250), the draft hood switch must be disconnected at the left side of the heater.

3. If the unit is in the low-profile outdoor configuration, remove the hex-head screws (see Figure 15) and lift the grate top assembly straight up.
4. Remove the screws that fasten the flue collector hold-down clamps and remove the clamps (see Figure 16).
5. Remove the flue collector assembly by lifting it out of the chassis.
6. Remove the screws that fasten the gap closures and put them aside.
7. Remove the three grommets.
8. Remove the drain valves and plug. There is one hex plug on the left side, near the rear of the jacket. The drain valves are located on the left side and right side of the heater (see Figure 9).
9. Remove the four screws that fasten the metal channels covering the capillary tube on the right side of the jacket, and lay the channels aside.
10. In the control compartment, find the manual reset high-limit switch box (see Figure 15) and loosen the screw on the top to remove the cover.
11. Loosen the screw that fastens the white wire and remove it from the terminal. Pull it out through the top of the case and separate the other white wire from the red wire coming from the fuse holder. Gently pull the two white wires out of the control compartment and coil them on top of the heat exchanger.
12. A temperature control sensing bulb is located in the front of the header on the inlet side and a manual reset hi-limit sensing bulb is located on the back side of the header on the outlet side (see Figure 17). Remove these sensing bulbs from the header. The following steps for removal apply to all sensing bulbs:
  - a. If there is more than one capillary tube coming out of the header, label the capillary tubes.
  - b. Loosen the screw on the capillary tube retaining clip, then gently pry the clip apart until it comes free from the temperature control (see Figure 18).
  - c. Pull the sensing bulbs out of the temperature control.
  - d. Gently pull the capillary tubes into the control compartment.
  - e. Pull the temperature sensing bulb out of the header, and temporarily route it to the front of the heater.

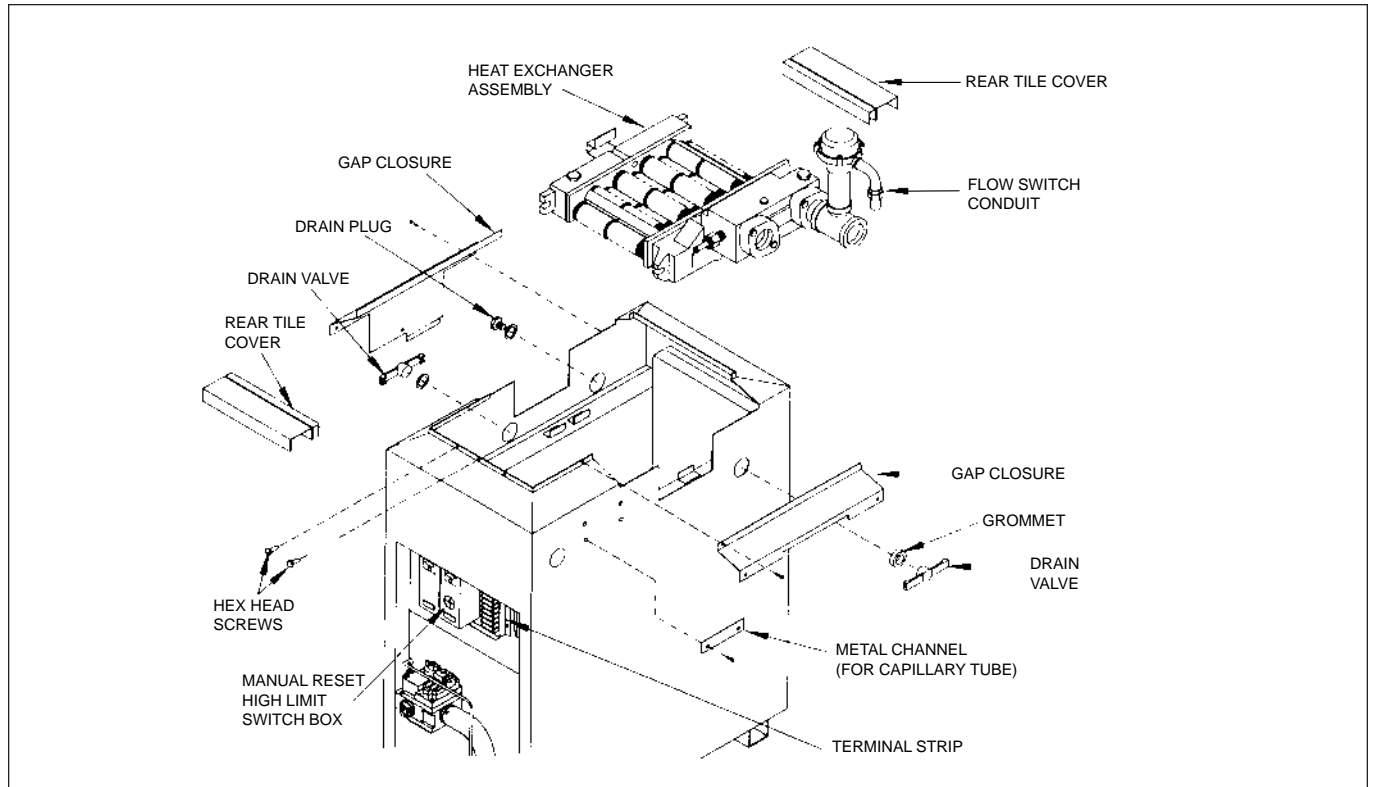

Figure 15. Heat exchanger reversal.

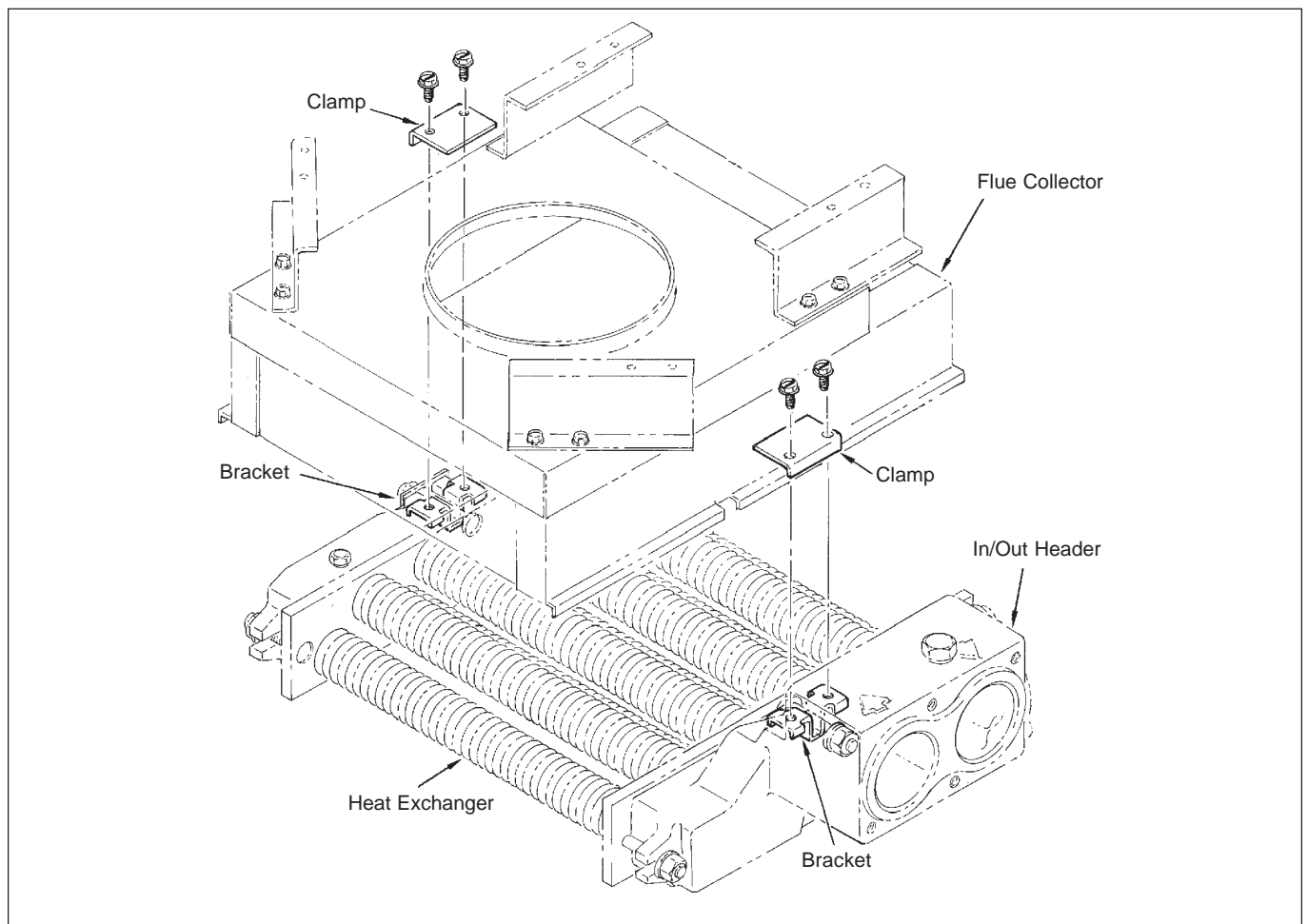

Figure 16. Flue collector Holddown Clamps.

13. Use a pair of diagonal cutters to cut the plastic tie around the wire bundle in the control compartment.
14. On the terminal strip, disconnect the two brown wires from No. 5 and No. 6 terminals.

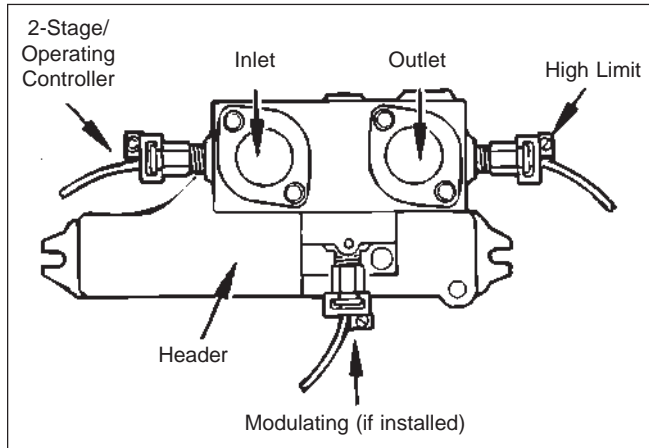

Figure 17. Sensory bulb locations.

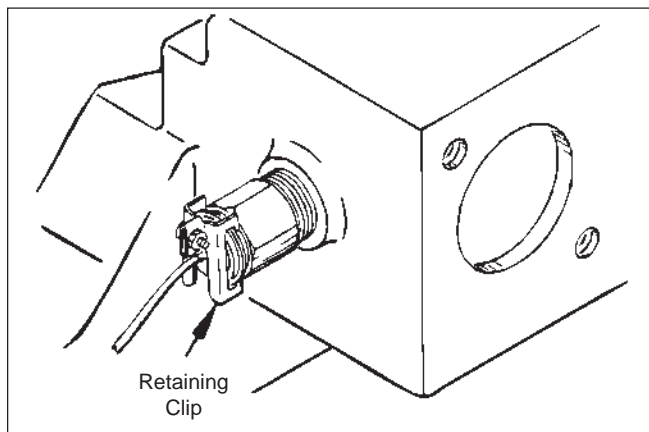

Figure 18. Retaining clip removal.

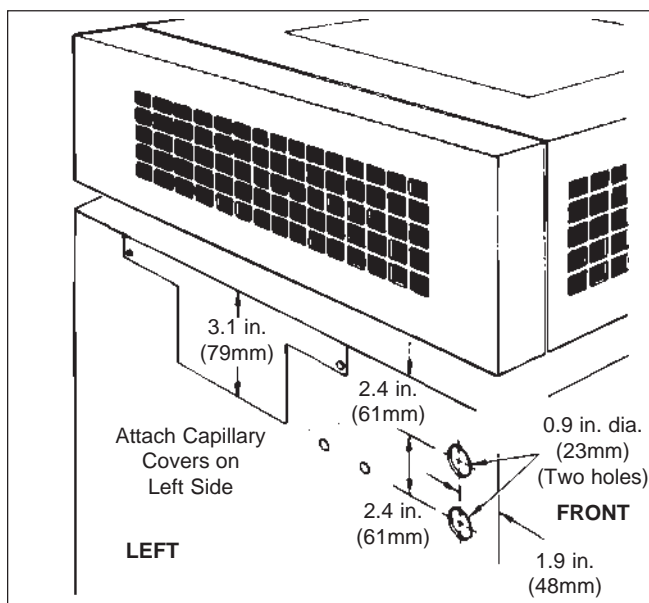

Figure 19. Hole location, left side.

15. Remove the flow switch conduit retaining clip and the elbow leading into the jacket.
16. Reach inside the control compartment and release the retaining nut in the upper right corner. The nut should only be finger-tight.
17. When the conduit is pulled away from the jacket, pull the two brown wires out of the control compartment. Coil the conduit and wires on top of the heat exchanger.
18. Use a chassis punch to put two 7/8 inch (22 mm) holes in the front left side of the jacket (see Figure 19).
19. Remove the front and rear tile covers (see Figure 15).
20. Lift out the heat exchanger assembly, turn it 180 degrees, and reseat the unit in the heater with the water connections on the left side.
21. Reinstall the front and rear tile covers.
22. Push the capillary tube(s) out through the lower hole in the left side of the jacket.
23. Install the sensing bulb(s) into the appropriate temperature control (keep in mind that the positions of the inlet and outlet have been reversed. The inlet is now behind the outlet).
24. Fasten the capillary tube(s) by squeezing the retaining clip together, then tighten the screw.
25. Feed the two brown wires through the top hole on the left side until the conduit elbow is against the jacket.
26. Fasten the conduit by sliding the retaining nut over the two brown wires (inside the control compartment) then screwing it down finger-tight on the conduit elbow.
27. Straighten the capillary tubing and fasten it to the side of the heater under the channel. Use the self-tapping screws to fasten the channel to the jacket.
28. Feed the two white wires into the control compartment. Attach one wire to the terminal in the manual reset hi-limit switch. If one is not installed, attach it to terminal No. 1. Connect the other wire to the red wire attached to the fuse holder.
29. Attach the two brown wires to terminals No. 5 and 6 on the terminal strip. Keep all wiring away from surfaces that will get hot during heater operation.
30. Replace the gap closures and tighten the screws securely.
31. Replace the three grommets and the cap.
32. Reinstall the drain plug and drain valves.
33. Slip the flue collector assembly back down inside the enclosure.

34. Carefully slip a hand inside to make sure there are no gaps between the heat exchanger and the flue collector.
35. Check to make sure the wiring is not pinched against sharp edges, or resting on the collector assembly.
36. Replace the two flue collector holddown clamps.
37. Replace the top assembly and fasten it with the hex-head screws.
38. Replace the front cover.
39. Reinstall the vent cap or drafthood if one was removed.
40. On indoor installations (sizes 175-250), insert the draft hood switch plug into the receptacle on the left side of the heater.

### 2F-2. Water Chemistry

Laars equipment is designed to be used in a variety of water conditions. With the proper pump, the water velocity in the heat exchanger tubes is kept high enough to prevent scaling from hard water, yet low enough to avoid erosion by soft water.

**NOTE:** It is possible to have hard and soft water in the same city. Check with the local water companies.

If an installer sees damage to any water handling equipment at the installation site, it should be repaired as soon as possible to help reduce maintenance costs. If there is erosion, resize the pump to reduce water velocity before the tube ruptures. If scaling is bad, set up a heat exchanger tube-cleaning maintenance schedule to prevent heat exchanger tube cracking and wear. Not fixing the condition will mean serious damage to the heater and the water system.

#### NOTES:

- In areas where the water supply is soft or corrosive, the heater must have cupronickel tubes in the heat exchanger.
- Laars does not warrant heat exchangers damaged by scaling, corrosion, or erosion.

### 2F-3. Freeze Protection

Although VW-PW heaters are design certified by the International Approval Services (IAS) (formerly American Gas Association [AGA] and Canadian Gas Association [CGA]) for outdoor installations, such installations are not recommended in areas subject to freezing temperatures unless proper precautions are taken. Consult the local factory representative or Laars for additional information.

### 2F-4. Water Hardness

Consider the water hardness when selecting a pump for the heater (see Table 3). Hard water needs a pump which can provide high flow to prevent scaling, while soft water needs low flow to prevent erosion.

Hardness Category	Grains per Gallon	Parts per Million
Soft	1 through 7.5	17 through 128
Normal	7.6 through 17	129 through 291
Hard	Over 17	Over 291

**Table 3. Water Hardness.**

### 2F-5. Pump Requirements

The VW heater does not have a factory installed pump (see Table 4 for pump performance requirements). The PW heater does have a factory installed pump which is for heater-to-tank circulation only.

VW and PW heaters are not designed for applications where the temperature of the water flowing through the heater remains below the dew point, 110°F (43°C).

The factory provided pump on the PW heaters, and the pumps recommended for field installation on VW heaters, are sized to provide proper circulation through the heater, and through the heater-to-tank circulation loop (see Figures 20 through 22).

If the heater-to-tank circulation loop does not contain more than 6 elbows or 30 feet (9.1 m) of pipe, the minimum pipe fitting should be 1-1/2 inches (38 mm). If the loop does contain more than 6 elbows or 30 feet (9.1 m) of pipe, the minimum size should be 2 inches (51 mm).

### 2F-6. Pressure Buildup in Water System

The water utility supply meter may contain a check valve, back flow preventer, or water pressure reducing valve that will create a closed water supply system. Contact the water supplier or local plumbing inspector on how to control this situation.

During the heating cycle of the heater, the water expands creating a pressure buildup in the water system. The pressure relief valve may discharge hot water under these conditions, causing a loss/waste of energy and a buildup of lime on the relief valve seat.

**NOTE:** Do not plug the relief valve.

There are two methods to prevent the relief valve from discharging hot water in a closed water system:

1. Install a pressure relief valve on the cold water supply line. Make sure that the discharge of this valve is directed to an open drain and protected from freezing.
2. Install a properly sized thermal expansion tank on the cold water supply line.

Model	Heat Exch. Passes	Water Category	Flow Rate		Pressure* Drop		Water Temp Rise	
			gpm	L/s	ft.	m	°F	°C
175	2	Soft	22	1.4	5.8	1.8	13	7
		Normal	34	2.1	11.2	3.4	8	4
		Hard	46	2.9	19.1	5.8	6	3
	4	Soft	11	0.7	4.9	1.5	25	14
		Normal	17	1.1	9.3	2.8	16	9
		Hard	23	1.5	15.9	4.8	12	7
250	2	Soft	22	1.4	5.8	1.8	18	10
		Normal	34	2.1	11.2	3.4	12	7
		Hard	46	2.9	19.1	5.8	9	5
	4	Soft	11	0.7	4.9	1.5	35	19
		Normal	17	1.1	9.3	2.8	33	18
		Hard	23	1.5	15.9	4.8	17	9
325	2	Soft	34	2.1	12.5	3.8	18	10
		Normal	34	2.1	12.5	3.8	18	10
		Hard	46	2.9	21.7	6.6	11	6
	4	Soft	17	0.7	10.4	3.2	36	20
		Normal	17	0.7	10.4	3.2	30	17
		Hard	23	1.5	18.1	5.5	22	12
400	2	Soft	34	2.1	13.3	4.1	19	11
		Normal	34	2.1	13.3	4.1	19	11
		Hard	46	2.9	23.4	7.1	14	8
	4	Soft	17	0.7	11.1	3.4	37	21
		Normal	17	0.7	11.1	3.4	37	21
		Hard	23	1.5	19.5	5.9	27	15

\*Pressure drop includes head loss of heat exchanger and through 30 feet (9.1 m) of pipe and normal fittings when heater is installed with storage tank. Pipe and fittings are assumed to be 1-1/2 inch (38 mm).

Table 4. Pump Performance Requirements.

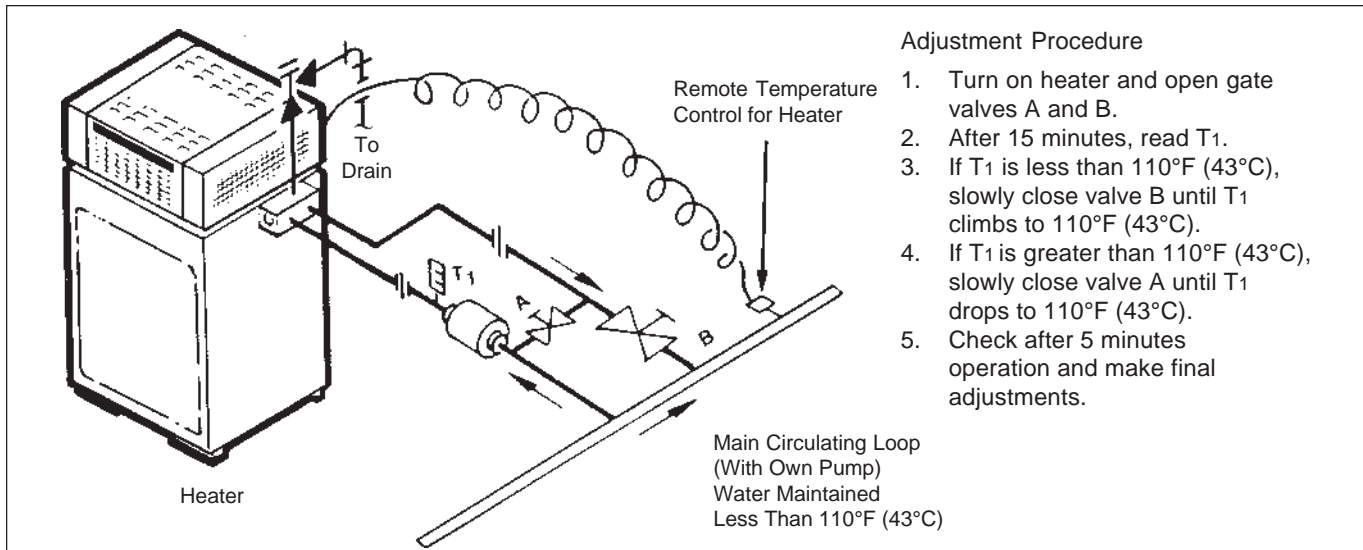

Adjustment Procedure

1. Turn on heater and open gate valves A and B.
2. After 15 minutes, read T1.
3. If T1 is less than 110°F (43°C), slowly close valve B until T1 climbs to 110°F (43°C).
4. If T1 is greater than 110°F (43°C), slowly close valve A until T1 drops to 110°F (43°C).
5. Check after 5 minutes operation and make final adjustments.

Figure 20. Cold water application.

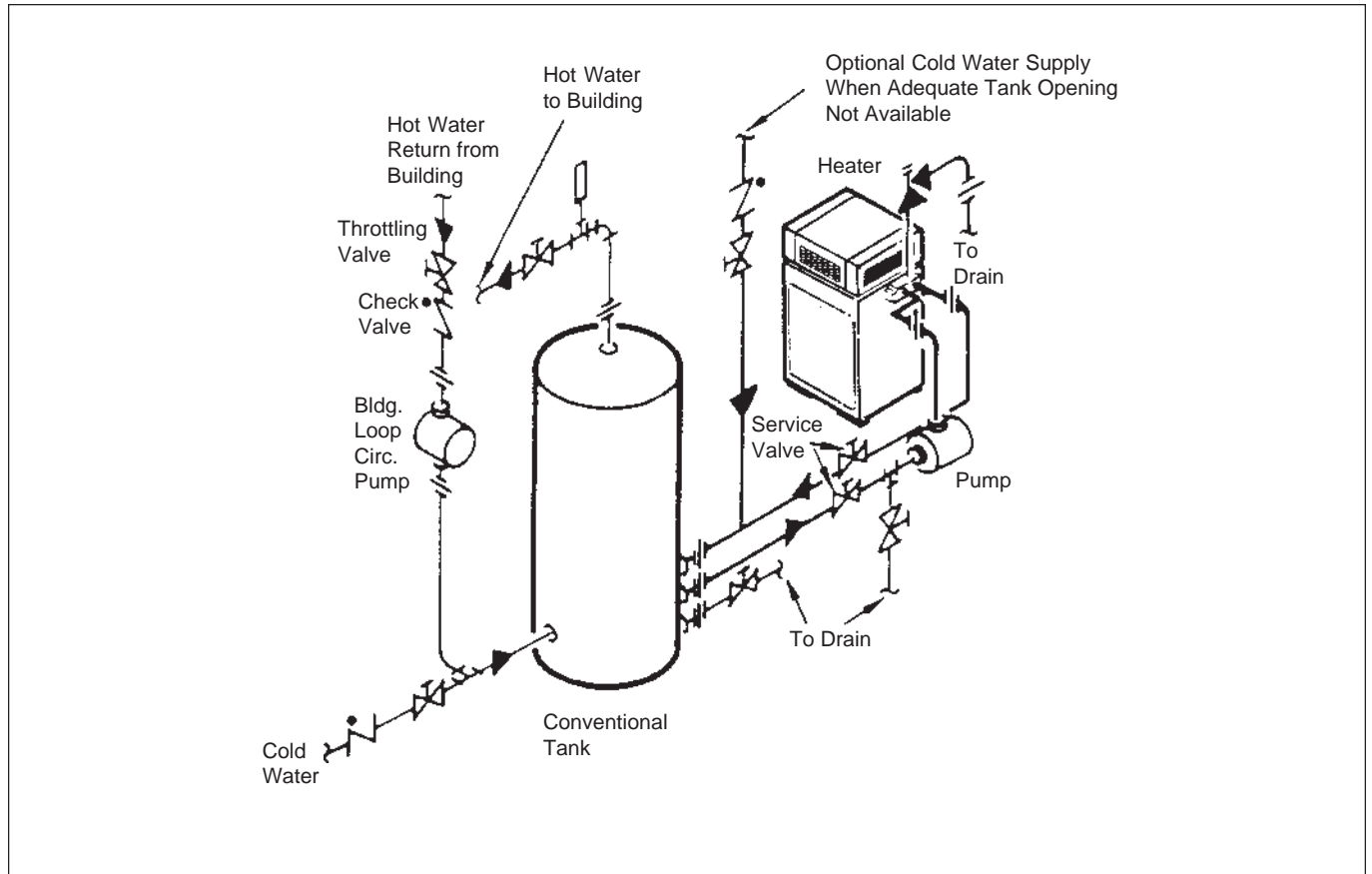

Figure 21. Hot water supply with vertical tank.

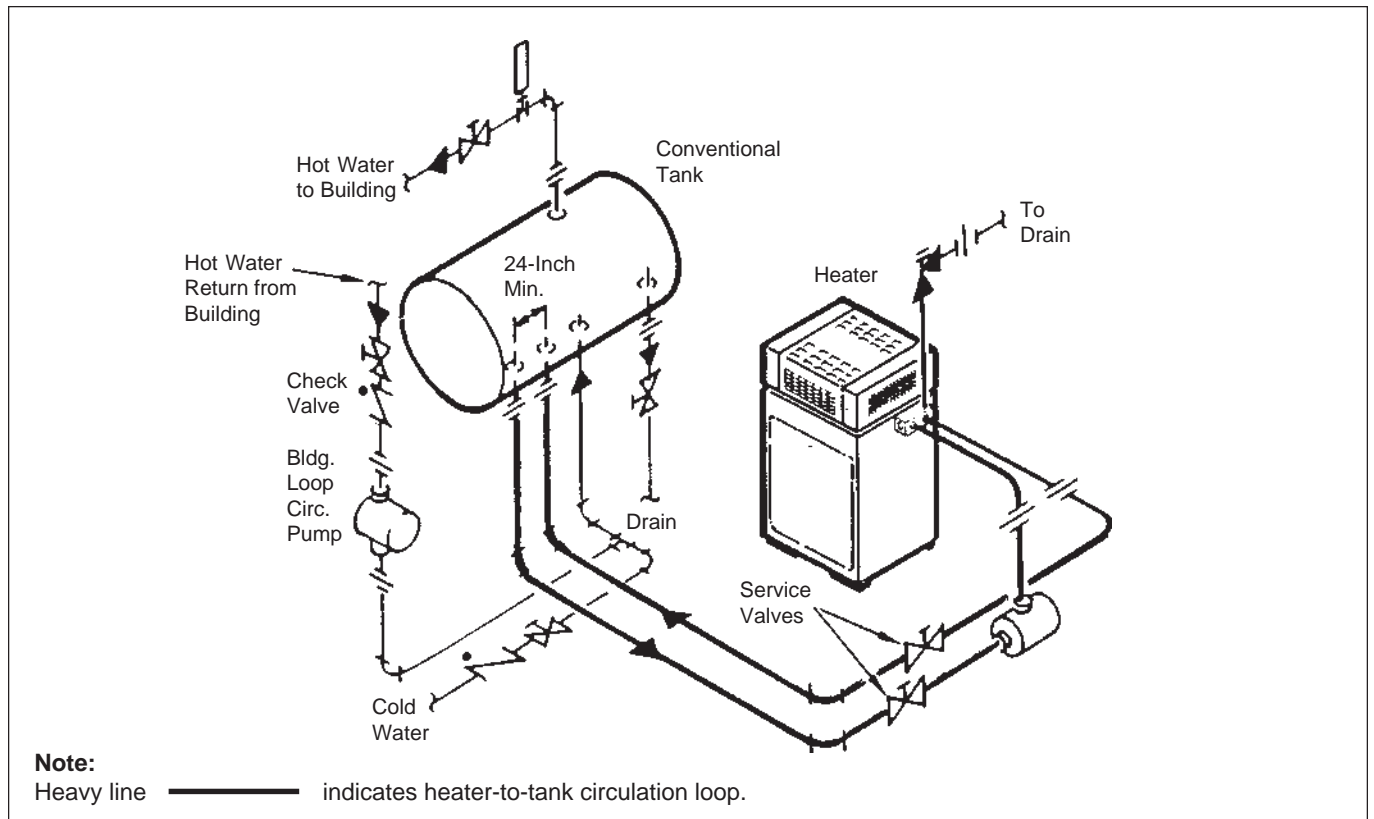

Figure 22. Hot water supply with horizontal tank.

### 2F-7. Pressure Relief Valve

The pressure relief valve must be installed in the tapped opening provided in the boiler header with its outlet piped to a drain or floor sink. Special attention must be given to relief valve settings in installations where the boiler is located on the ground floor of a tall building, or where the operating temperature of the boiler is above 210°F. In both instances, the static pressure of the system is elevated, and could cause the relief valve to leak. Where no special setting of the relief valve is ordered, the factory will furnish a 125 psi setting.

#### **⚠ WARNING**

Hot water can scald! Hot water can produce third degree burns in 6 seconds at 140°F (60°C) and in 30 seconds at 130°F (54°C).

### 2F-8. Water Pressure

Keep the water pressure in the system above 30 psi (207 kPa). If the system pressure drops below 30 psi (207 kPa), it could damage the heater through lack of circulation. If for any reason, the water is turned off temporarily, to service the equipment for example, airlock could be a problem when the heater is turned back on. To eliminate the airlock, open the pressure relief valve (see Figure 23) and allow the air to bleed out until water starts to flow. As soon as full circulation is restored, the trapped air will be released through the hot water faucets.

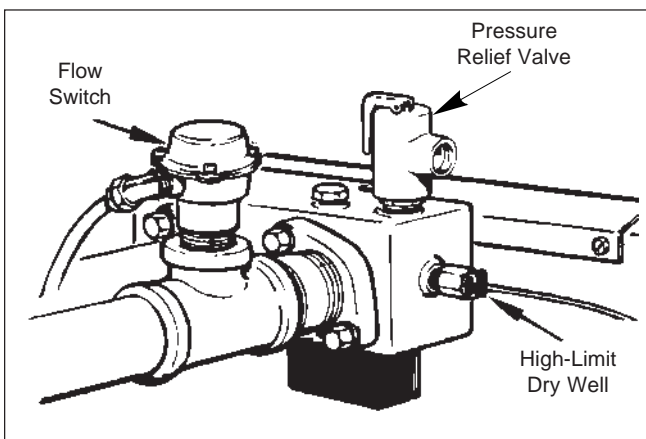

Figure 23. Pressure relief valve.

### 2F-9. Pump Installation (Model VW)

1. Install a properly sized pump to provide water circulation between the heater and the storage tank.
2. Size the pump to avoid an excessive temperature rise (see Table 4), and to provide the correct flow for prevailing water hardness conditions.
3. Install the pump in a cool location. The life of the pump can be shortened by exposure to excessive heat. If the pump is equipped with a thermal

protection device, excessive heat may trip the thermal switch. This could cause the pump to shut down intermittently, resulting in rapid scaling of the heat exchanger.

4. If designed for floor mounting, install pump securely on concrete block or pad at least 6 inches (152 mm) above floor level. This will prevent flooding of the motor when the floor is washed.
5. Do not suspend floor mounted pumps from piping.
6. Plumb piping to avoid putting strain on the pump casing.
7. Check the oil level in the pump before starting the heater. Oil the pump every three months. Oil pumps located in excessively hot or dusty locations once a month. Self-lubricating pumps do not require oiling.
8. Fill the bearing assembly to the lower level of the overflow vent.
9. Add 5 or 6 drops of oil to the front and rear of the motor. Use 20W non-detergent oil.

### 2F-10. Storage Tank Installation

1. Be sure the floor is structurally capable of supporting the tank when it is filled with water, and is waterproof.
2. Place the tank so that manholes, inspection covers, nameplates and drain valves are accessible.
3. Be sure the tank is suitable for the water in the system. Some water is corrosive and requires a protected tank. Most tanks are available with glass, plastic, or galvanized linings.
4. If the tank is glass-lined, it should be equipped with a suitable magnesium anode. It is a good practice to replace the anode when it is approximately 50 percent used. The factory warranty on a glass-lined tank may be void if a satisfactory anode is not in place at the time of a failure or if it is consumed by cathodic action.
5. The tank must be lined if a water softener is installed in the system.
6. Make sure the tank connections in the heater-tank circulating loop are the proper size (see Section 2F-5). If tappings are smaller than the recommended pipe size, a larger pump may be required. Consult the factory if in doubt.
7. Install a pipe in the tank drain fitting that goes to a floor sink, and install a drain valve. If a floor sink is not available, install a hose bib.
8. Hot water tanks in an existing installation are likely to have silt deposits on the bottom. Therefore, it is important to extend the pump suction pipe in the tank to a position near the top. Pipe the return from the heater to the bottom of the tank.

### 2F-11. Thermal Circulation of Hot Water in Cold Water Supply Lines

Under certain circumstances, thermal circulation will occur in the cold water pipe supplying the water to the heating system. This happens in a multi-story building when the cold water pipe rises from its connection to the system. To correct the problem, a check valve in the cold water line supplying the heater will prevent thermal circulation, and a small expansion tank will permit heated water to expand without popping off the relief valve.

## 2G. Gas Supply and Piping

### 2G-1. General Instructions

Review the following instructions before continuing the installation.

**⚠ WARNING**

The conversion of heaters from natural gas to propane gas, or propane to natural, must be done by a professional service technician. Laars provides kits and detailed instructions for converting the heater. Changing burner and/or pilot orifices is prohibited. The installer must add and sign a gas conversion tag when the conversion is made.

1. Gas piping installation must be in accordance with the latest edition of ANSI Z223.1. In Canada, the installation must be in accordance with CAN1-B149.1 or .2 and all local codes that apply.
2. Check the rating plate to make sure the heater is fitted for the type of gas being used. Laars heaters are normally equipped to operate below a 2000 foot (609 m) altitude. Heaters equipped to operate at higher altitudes have appropriate stickers or tags attached.
3. If a gas pressure regulator is required, the installation must be in accordance with the latest edition of ANSI Z223. In Canada, the installation must be in accordance with CAN1-B149.1 or .2 and all local codes that apply.
4. The figures in Table 5 should be used to size the gas piping from the gas meter to the heater.
5. Install a sediment trap (drip leg) ahead of the gas controls (see Figure 24 ). Fit the trap with a threaded cap which can be removed for cleaning.
6. Install a manual gas shutoff valve for service and safety. Check the local codes.
7. Disconnect the heater and its individual shutoff valve from the supply gas system during pressure test of the system at pressures higher than 1/2 psi (3.4 kPa).
8. Gas supply pressures to the heater are listed in Table 6.

Distance from Gas Meter or Last Stage Regulator						
Boiler Size	0-100 feet 0-30 m		100-200 feet 30-60 m		200-300 feet 60-90 m	
	Nat.		Nat.		Nat.	
	in.	mm	in.	mm	in.	mm
175	1	25	1¼	32	1¼	32
250	1¼	32	1¼	32	1½	38
325	1¼	32	1½	38	1½	38
400	1¼	32	1½	38	2	51

**Notes:**

1. These numbers are for natural gas (0.65 Sp. Gr.) and are based on ½ inch (13mm) water column pressure drop. Check supply pressure with a manometer, and local code requirements for variations. For liquefied petroleum gas, reduce pipe diameter one size, but maintain a ½ inch (13mm) minimum diameter.
2. Check supply pressure and local code requirements before preceding with work.
3. Pipe fittings must be considered when determining gas pipe sizing.
4. For propane gas: Reduce pipe diameter one size, but maintain a ¾ inch (19mm) minimum diameter.

**Table 5. Natural Gas and Propane, Pipe Size Requirements.**

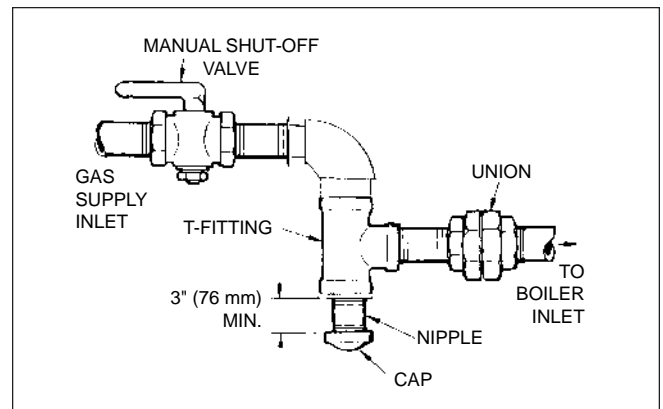

**Figure 24. T-Fitting and sediment trap.**

Supply Pressure Water Column	Natural Gas		Propane Gas	
	in.	mm	in.	mm
Minimum	6.5	165	11	279
	See Rating Plate			
Maximum	9	229	14	356

**Table 6. Gas Supply Pressure Requirements.**

**NOTE:** The heater and all other gas appliances sharing the heater gas supply line must be firing at maximum capacity to properly measure the inlet supply pressure. Low gas pressure could indicate an under-sized gas meter and/or obstructed gas supply line.

9. Do not exceed the maximum inlet gas pressures specified. Excessive pressure will result in

- damage to the heater's gas controls. The minimum pressures specified is for gas input adjustment.
- The correct burner manifold gas pressure is stamped on the rating plate. The regulator on the gas valve is preset at the factory, and does not normally need adjustment.
  - Before operating the heater, test the complete gas supply system and all connections for leaks using a soap solution.

### **⚠ Caution**

Since some leak test solutions (including soap and water) may cause corrosion or stress cracking, rinse the piping with water after testing.

## **2G-2. Special Precautions for Propane Gas**

Liquefied petroleum (LP) gas is heavier than air. Therefore, do not install heaters using LP gas in a pit or locations where gas might collect. Locate heaters a safe distance from LP gas storage and filling equipment. Consult local codes and fire protection authorities about specific installation restrictions.

## **2H. Electrical Wiring**

### **⚠ WARNING**

Electrically ground the heater in accordance with the latest edition of the National Electrical Code, ANSI/NFPA 70. In Canada, use C22.1. Do not rely on the gas or water piping to ground the metal parts of the heater. Often, plastic pipe or dielectric unions isolate the heater electrically. Service and maintenance personnel who work on or around the heater may be standing on wet floors and could be electrocuted by an underground heater.

- Check heater wiring and pump for correct voltage, frequency, and phase. Check to make sure heater is wired for 120 volts alternating current (VAC). If 240 VAC, contact local factory representative or Laars.
- Wire the heater and pump exactly as shown in the wiring diagram supplied with the heater. See Figure 26 and 27 for a typical example of a wiring diagram.
- Electrically interlock the pump and heater so the heater cannot come on unless the pump is running.

- Connect all field-installed devices (draft switches, relays, timers, outdoor temperature reset devices, etc.) (see Figs. 19 and 20) to the heater wiring at points labeled Field Interlock.

## **2I. Combined Space Heating/Potable Water Heating Systems**

### **2I-1. Combined Space Heating**

The VW and PW heaters are not to be used as a source of heat for a combined space heating system.

### **2I-2. Potable Water Heating**

Do not use water piping, fittings, valves, pumps, and any other components which are not compatible with potable water.

Do not connect the heater, which will be used to supply potable water, to any heating system or components previously used with a non-potable water heating system.

Do not add heater treatment or any chemicals to the heating system piping, since the piping contains water for potable use.

Do not use solder containing lead in the potable water lines.

If the space heating system requires water temperatures greater than the water temperature for potable hot water use, a tempering valve (see Figure 25) or other means should be installed in the potable hot water supply line to limit the risk of scald injury.

Some jurisdictions may require a backflow preventer in the cold water line. In such cases, the temperature and pressure relief valve may discharge water due to expansion. A diaphragm type expansion tank will normally eliminate this condition. Follow the manufacturer's instructions for installation of the expansion tank.

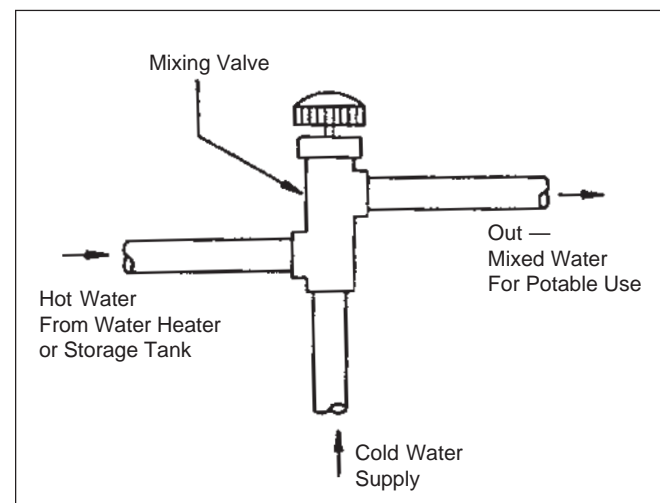

**Figure 25. Installation of tempering valve.**

## SECTION 3. Operating Instructions

### 3A. Normal Operating Sequence

**NOTE:** Safe lighting and other performance criteria were met with the gas manifold and control assembly installed on the heater during tests specified in ANSI Z21.13.

#### WARNINGS

Vent pipes, drafthoods, and heater tops get hot! These surfaces can cause serious burns. Do not touch these surfaces while the heater is in operation. Adding a vent cap reduces the temperature on the top.

For your safety, when starting the heater, keep your head and face well away from the lower firebox opening to prevent any risk of personal injury.

**LP GAS:** To avoid possible injury, fire and explosion, read and follow these precautions and all instructions on this heater before lighting. This heater uses LP gas which is heavier than air and will remain at ground level if there is a leak. Before lighting, sniff at ground level.

If you smell gas, follow these rules:

1. DO NOT light matches. DO NOT turn electric lights or switches on or off in area. DO NOT use an electric fan to remove the gas from area.
2. Shut off gas at LP tank.
3. Telephone gas company and fire department for instructions. Give your name, address and phone number.

If your LP tank runs out of fuel, turn off gas at the heater. After the tank is refilled, the heater must be relit in accordance with the instructions found on the inside of the heater. DO NOT attempt repairs on the gas control or heater. Tampering is dangerous and voids all warranties.

### 3B. Start-Up Procedure

Lighting instructions can be found on the inside of the heater. To start up the heater:

1. Make sure the system pump is running and there is water flow.
2. Remove the control access panel.
3. Set the temperature control (see Figure 28) to its lowest setting.
4. Turn electric power to the appliance to off.

5. Turn manual gas valve off.
6. Wait 5 minutes to clear out any gas, then smell for gas, including near the floor. Be sure to smell next to the floor because some types of gas are heavier than air and will settle on the floor.

#### Caution

This heater is equipped with an ignition device which automatically lights the burner. Do not try to light the burner by hand.

7. Turn manual gas valve on.
8. Reset all safety devices (some units have manual resets on hi-limit switch, low water cutoff, etc.).
9. Replace control access panel.
10. Turn electric power to the heater on.
11. Set temperature control to desired setting.
12. If the heater will not operate:
  - a. Turn gas to heater off following the instructions found on the inside of the heater and call a qualified service technician or gas supplier.
  - b. Turn main electrical switch off.
  - c. Close all manual gas valves.

### 3C. Setting the Temperature Controls

The hi-limit switch is factory set and should not be adjusted.

#### WARNING

Adjusting the temperature control past the recommended setting can result in a scalding injury. Hot water can produce third degree burns in 6 seconds at 140°F (60°C) and in 30 seconds at 130°F (54°C).

Water temperature can be adjusted at the temperature control (see Figure 28). The temperature control is adjusted to its lowest setting when it is shipped from the factory. The 130°F (54°C) setting is the recommended starting point for setting the temperature control.

The recommended setting will result in satisfactory energy savings. Lowering the temperature may result in reduced energy costs. Connecting the heater to a separate storage vessel and lowering the temperature setting, may reduce energy losses during standby periods when hot water is not being used, and may meet normal hot water needs. For increased hot water usage, a higher temperature setting may be necessary to meet increased demand. Reset the temperature setting to a lower level after periods of increased usage are over.

# IGNITION SYSTEM NO. 1 - STANDING PILOT ON/OFF OR MECHANICAL MODULATION

Volume Water Heaters (325-400) Version B  
Natural or Propane Gas

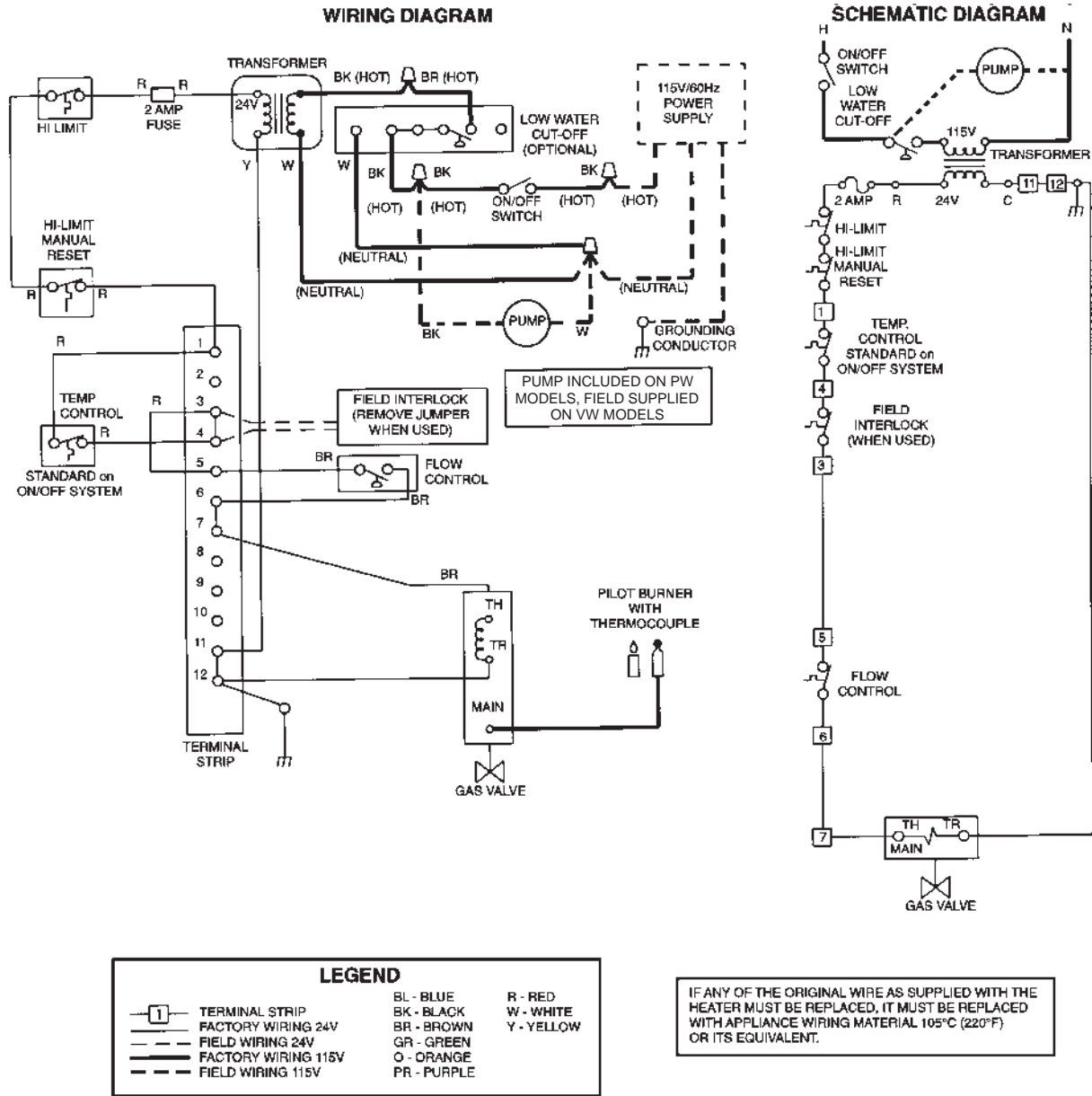

Figure 26. Typical example of wiring schematic, System 1.

# IGNITION SYSTEM NO. 12 - ELECTRONIC IGNITION ON/OFF OR MECHANICAL MODULATION

Volume Water Heaters (325-400) Version B  
Natural or Propane Gas

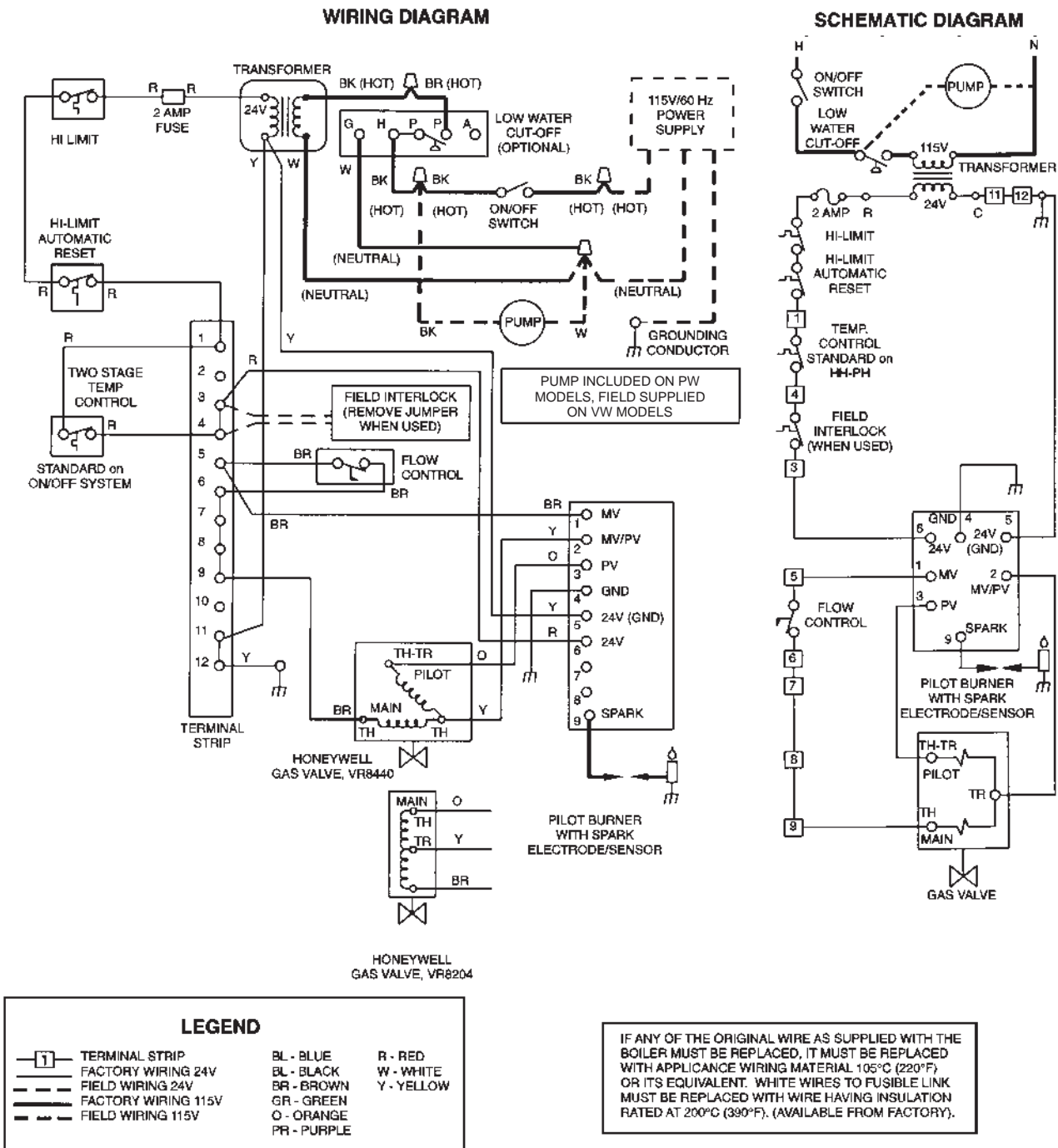

Figure 27. Typical example of wiring schematic, System 12.

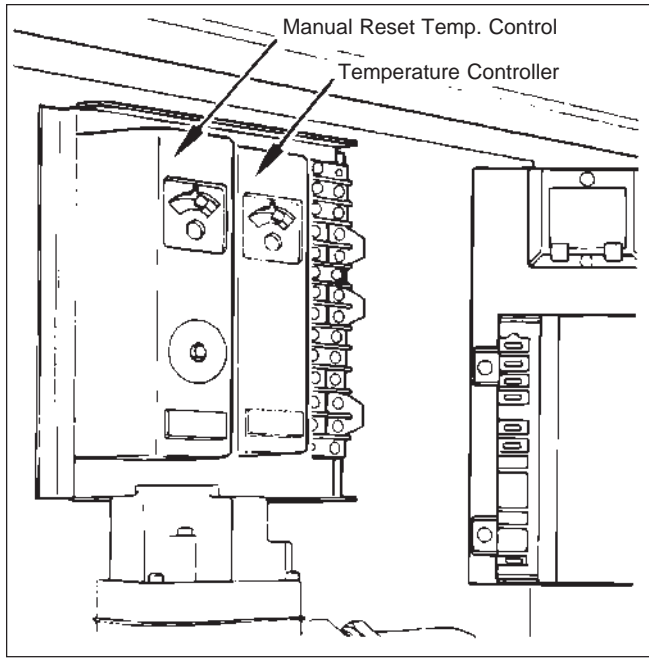

Figure 28. Temperature controls.

Heaters on constant flow have the temperature control sensor bulb in the heater inlet and the manual reset hi-limit sensing bulb located in the heater outlet. Set the temperature control dial (see Figure 28) at the designed system temperature. Set the hi-limit switch 40 to 50°F (4 to 10°C) above the supply temperature to the system.

Heaters on intermittent flow have the temperature control sensing bulb in the storage tank and the manual reset hi-limit sensing bulb located in the heater outlet. Set the hi-limit switch 40 to 50°F (4 to 10°C) above the supply temperature to the system.

**3D. Adjustment for Minimum Input Rate (models with modulating gas valve)**

Adjust the red knob on the modulating gas valve to the dial number for the desired water temperature (see Table 7). Adjusting the red knob to number "1" sets the gas flow rate to minimum. The control is factory set at "5" which is satisfactory for most installations.

Dial No.	Temp.	
	°F	°C
1	120	49
2	127	53
3	135	57
4	142	61
5	150	66
6	157	69
7	165	74
8	172	78
9	180	82

Table 7. Water Temperature Setting.

**3E. Hi-Limit Switch Checkout**

After running the heater for a long enough period, bring the water temperature within the range of the hi-limit switch and slowly back off the high limit setting until the heater shuts off. The main burners should reignite when the hi-limit switch is reset and turned back up to its original setting. The heater should now run until it shuts off automatically on operating control.

Should overheating occur or the gas supply fail to shut off, turn off the manual gas control valve to the heater.

**3F. Shut-Down Procedure**

Shut down the heater following the instructions found on the inside of the heater.

Where there is a danger of freezing, shut off the water supply and remove the drain plugs on both sides of the heater jacket. Drain every part of the system subject to damage from freezing temperatures.

**SECTION 4. Maintenance**

**4A. General Instructions**

1. Oil the water circulating pump in accordance with the manufacturer's instructions.
2. If a strainer is used in a pressure reducing valve or in the piping, clean it every 6 months in accordance with the manufacturer's instructions.
3. At startup and every 6 months after, look at the pilot and main burner flame (see Figure 29). If the flame has the appearance of sooting tips, check for debris near orifices. Call service technician.
4. Inspect the venting system for blockage, leakage, and corrosion at least once a year.
5. Keep the heater area clear of combustible material, gasoline, and other flammable liquids and vapors.
6. Be sure all combustion air and ventilation openings are not blocked.
7. Check for black carbon soot buildup on the external surfaces of the heat exchanger every 6 months.
8. Do not use the heater if any part has been under water. Replace any part of the control system and any gas control which has been under water.

**NOTE:** After installation and first startup, check the heat exchanger for black carbon soot buildup after the following periods of operation: 24 hours, 7 days, 30 days, 90 days, and once every 6 months thereafter.

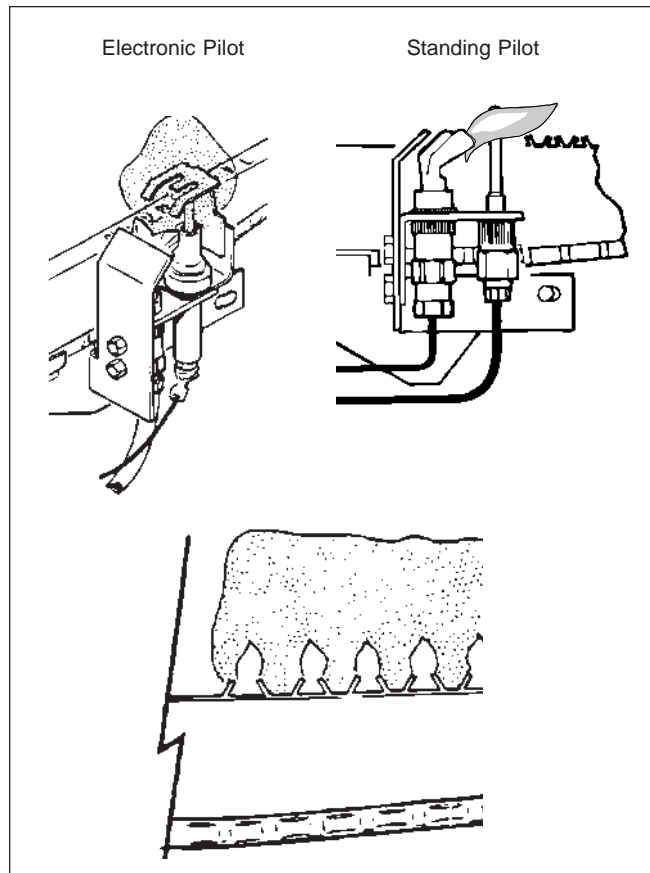

Figure 29. Flame patterns.

#### 4B. Replacement of Gas Controls

The gas and electric controls installed on the heaters are designed for both dependable operation and long life. Safe operation of the heater depends on their proper functioning.

**NOTE:** The warranty does not cover damage caused by lack of required maintenance or improper operating practices.

#### **⚠ WARNING**

Never attempt to repair the gas valve. Such attempts will void the warranty, and could lead to dangerous results.

If the gas valve is found to be defective, replace it by following these instructions.

1. Turn off electrical power to the heater.
2. Turn off the main gas supply at the manual gas cock outside the heater jacket or at the meter.
3. Remove the front access door on the heater.
4. Turn off the gas valve to heater following the instructions found on the inside of the heater.
5. Disconnect the service union in the gas line, and unscrew the main gas pipe from the gas valve (see Figure 30).

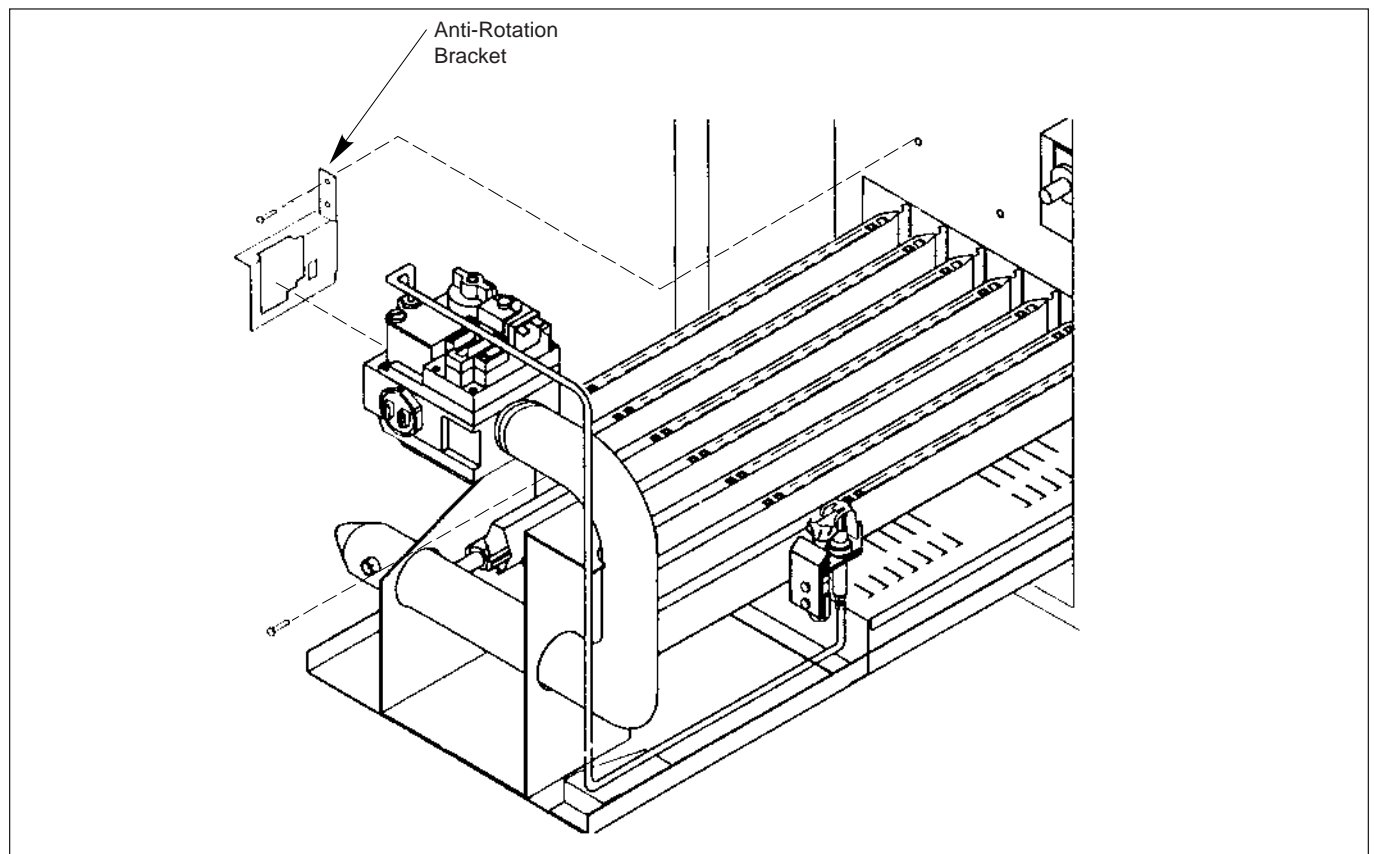

Figure 30. Gas valve/burner replacement.

6. Remove the two screws that fastens the anti-rotation bracket on the left side of the gas valve (see Figure 30).
7. Remove the pilot gas tube and copper thermocouple shield, if present, from the gas valve.

**⚠ Caution**

Label all wires prior to disconnection. Wiring errors can cause improper and dangerous operation.

8. Tag and remove all wires from the gas valve terminals.
9. Pull the burner tray out of the heater (see Figure 30).

**NOTE:** Due to sharp edges on the metal burners, wear protective gloves for the next steps.

10. Hold the gas burner or pilot burner firmly, and push it away from the manifold until it is clear of the orifice. Slide the burner to be replaced out of the burner tray (see Figure 31).

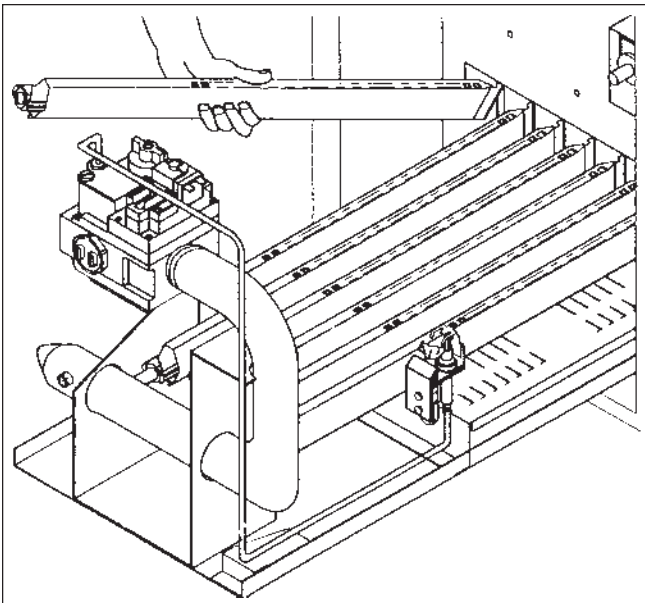

**Figure 31. Burner removal.**

11. To replace the gas burner, insert the burner into the slot at the rear of the burner tray, line it up with the proper orifice and snap it into position.
12. To replace the pilot burner, install the pilot assembly on the new pilot burner and install it in the burner tray.
13. Slide the burner tray back into the heater and fasten it with two screws.
14. Screw the new gas valve onto the manifold pipe. Make sure the arrow on the bottom of the gas valve that indicates the direction of gas flow is in the proper direction. Also make sure the brass fitting is on the right side.

15. Connect the pilot gas tube to the pilot assembly and the gas valve.
16. Install the anti-rotation bracket to the inner panel and fasten with two screws (see Figure 30).
17. Install manifold bracket and fasten with screws.
18. Connect the service union in the gas line, and screw the main gas pipe to the gas valve (see Figure 30).
19. Turn on gas valve following the lighting instructions found on the inside of the heater.
20. Turn on the main gas supply at the manual gas cock or the meter.
21. Check the system for leaks using a soap solution.

**⚠ Caution**

Since some leak test solutions (including soap and water) may cause corrosion or stress cracking, rinse the piping with water after testing.

22. Reconnect the electrical wires to the gas valve in accordance with the wiring diagram found on the inside of the heater.
23. Install the front access door on the heater.
24. Turn all electrical power to the heater on.

## 4C. HEAT EXCHANGER

### 4C-1. Inspecting the Heat Exchanger

To check the scale buildup, periodically inspect the tube having the highest temperature as follows:

1. Open the drain valve on the left side of the heater.
2. Remove the large, hex-head plug located on the right side of the heater under the in/out header (see Figure 32). Perform this inspection after 60 days of and after 120 days of operation. This will establish a regular inspection routine.

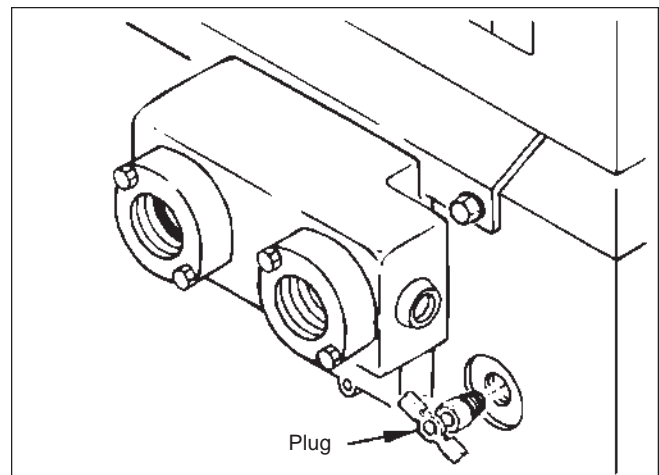

**Figure 32. Scale inspection.**

### 4C-2. Cleaning the Heat Exchanger

An inspection and cleaning of the complete heat exchanger can only be done by removing it from the heater.

1. To remove the heat exchanger, refer to Section 2F-1.

#### **⚠ Caution**

Black carbon soot buildup on a dirty heat exchanger can be ignited by a random spark or flame. To prevent this happening, dampen the soot deposits with a wet brush or fine water spray before servicing the heat exchanger.

2. Remove the heat baffles and check for a light accumulation of soot or corrosion on the outside of the heat exchanger tubes.

**NOTE:** While the heat exchanger is out of the heater, inspect the firewall refractory insulation blocks for cracks, wear, and breakage. Replace if necessary.

3. Use a wire brush to remove soot and loose scale from the heat exchanger. Do not use water or compressed air for cleaning.

**NOTE:** Use only the correct carbide tipped reamers which are available from Laars.

4. Ream the insides of the tubes (see Figure 33).
5. Pull the reamer out frequently to remove lime powder and prevent the drill from binding in the tube.
6. Install new gaskets. Do not reuse the old ones.
7. Tighten the header bolts progressively, starting with the two center bolts. Maximum torque is 20 inch pounds (27 Nm). Do not over-torque.

8. Pressure test the heat exchanger for leaks with city water supply before re-installing (see Figure 33).
9. When placing the heat exchanger back in the heater, carefully hold the refractory insulation blocks apart and lower the heat exchanger into place. Be sure the sheet metal covers, which protect the insulation blocks, are replaced carefully.
10. If a header bolt is stripped, drive it out of the header plate and replace it (see Section 6, Parts List).
11. To reinstall the heat exchanger, refer to Section 2F-1.

## SECTION 5. Troubleshooting and Service

### 5A. Gas Pressure Tests

Use the following procedures to check the main gas and manifold regulated gas pressures. A manometer kit is available from Laars and instructions for its use are included in the kit. A dry gas pressure gauge may also be used for either test.

#### 5A-1. Checking the Main Line Gas Pressure

1. Attach a manometer (or a dry gas pressure gauge) to heater jacket (see Figure 34).
2. Open both columns on the manometer.
3. Use shutoff valve outside the heater jacket to shut off all gas supply to the heater.

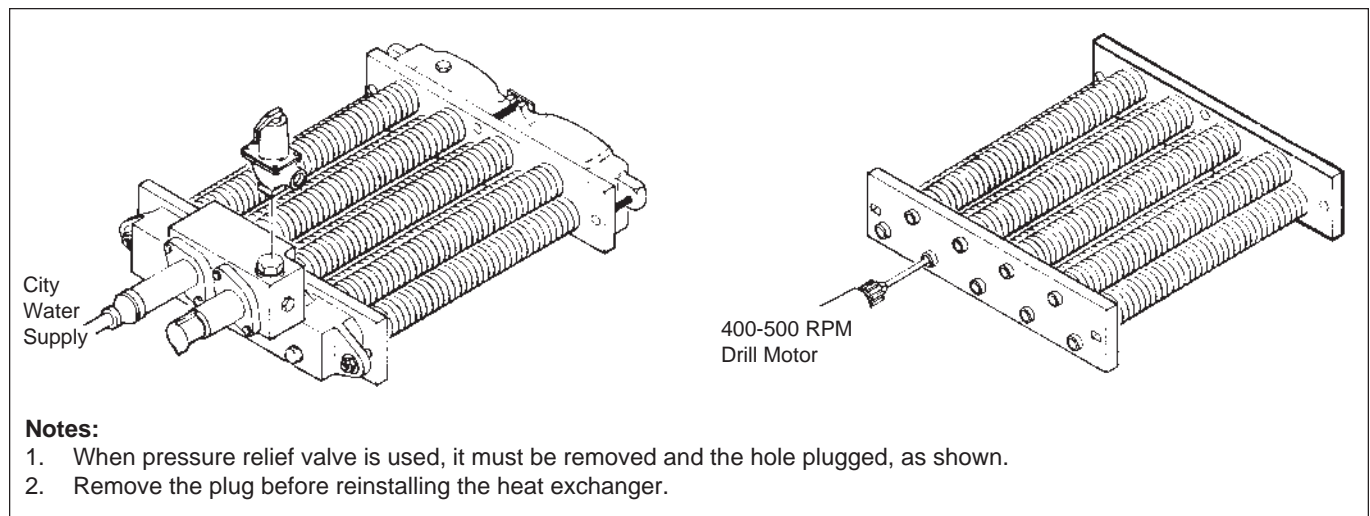

Figure 33. Heat exchanger tube cleaning.

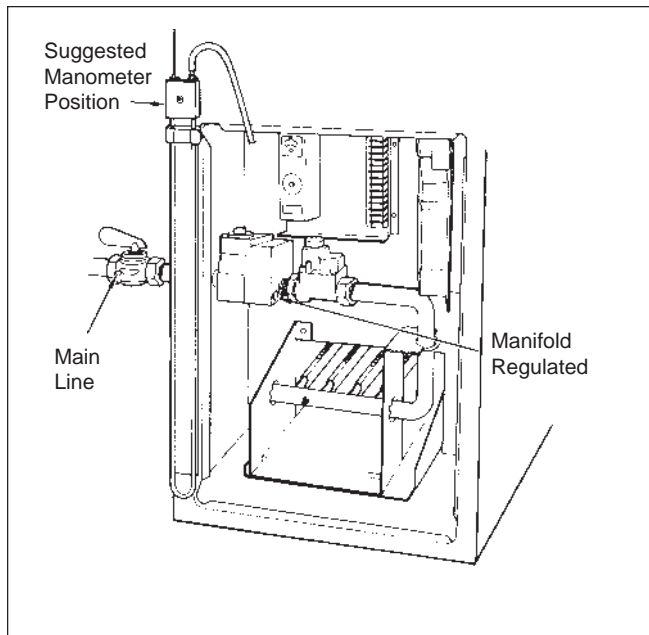

Figure 34. Gas pressure test.

4. Remove the 1/8 inch (3.2 mm) National Taper Pipe (NPT) test plug in the shutoff valve and replace it with the 1/8 inch (3.2 mm) NPT fitting from the manometer kit.
5. Attach one end of the manometer hose to the fitting on the gas valve and the other end to the manometer.
6. Open gas supply valve to the heater and set the temperature control high enough to call for heat.
7. With the main burners firing, the manometer reading should be between 5 and 10 inches (127 and 254 mm) W.C.

#### 5A-2. Checking the Manifold Regulated Gas Pressure

1. Attach a manometer (or a dry gas pressure gauge) to heater jacket (see Figure 34).
2. Open both columns on the manometer.
3. Use shutoff valve, on outside of heater jacket, to shut off all gas supply to the heater.
4. Remove the 1/8 inch (3.2 mm) NPT test plug on the outlet side of the gas valve, and replace it with the 1/8 inch (3.2 mm) NPT fitting from the manometer kit.
5. Attach one end of the manometer hose to the fitting on the gas valve and the other end to the manometer.
6. Turn on gas supply to the heater, and set the temperature control high enough to call for heat.
7. Turn toggle switch to ON. This should activate the main burners.

8. The manometer reading should be 4 inches (102mm) W.C. for natural gas and 9 inches (229mm) W.C. for propane gas.
9. Turn the toggle switch to OFF.
10. Shut the system down following the instructions found on the inside of the heater.
11. Disconnect the manometer tubing from the gas valve and replace the 1/8 inch (3.2 mm) NPT fitting with the original plug.

### 5B. Electrical Troubleshooting

This section describes procedures for checking the electrical power and control components of the heater. Read all of these procedures before starting repairs.

Problems with heaters not firing are usually caused by something reducing water flow through the heater, causing the protective switches in the heater system to shut down the heater.

The following tools are required for proper service and problem diagnosis of the heater and heating system.

1. Gas pressure test kit with range from 0 to 14 inches (0 to 356 mm) W.C.
2. Electric meter(s) with the following ranges:
  - a. 0 to 500 volts VAC
  - b. 0 to 2000 ohms ( $\Omega$ )
  - c. 0 to 20 microamps (mA)
  - d. 0 to 50 millivolts (mV)
3. Tube cleaning kit with a reamer, stainless steel brush, speed handle, and handle extensions.
4. A pressure gauge and a thermometer with proper ranges for heater operation.

#### 5B-1. Heater Does Not Come On

**Important:** Disconnect power to the heater or pull the RED wire off the transformer secondary before removing or replacing any component or wire connection.

#### WARNING

If power is not disconnected, jumpering gas valve or accidental grounding of the wire harness, or component terminals to the heater frame or jacket could cause the ignition control fuse to blow or may cause the heater to fire, resulting in injury or property damage.

1. Make sure the heater has been properly installed.
2. Make sure the pump is not airlocked, clogged or otherwise inoperative.

3. Make sure the gas valve is on and there is gas pressure in the line.
4. Check all electrical connections and wiring. Finding a loose connection or a charred wire can save a lot of time and money.
5. Check the fuse inside the black, twist-lock fuse holder. If it is burned, replace it with a 2-amp fuse (Part No. E0084400). If there is a short, the cause of the short must be found and repaired. Do not jumper or bypass the fuse.
6. Make sure the electrical circuit to the heater is on.
7. Make sure the toggle switch on the right side of the heater is on.
8. Make sure the temperature control is set high enough to call for heat.
9. Make sure the manual reset on the safety controls (e.g., low water cutoff, hi-limit switch, etc.) has not tripped. If it has, reset it.

If the pump is circulating water, and the rest of these items check out all right, the trouble could be in the heater control system.

### Caution

Label all wires prior to disconnection when servicing controls. Wiring errors can cause improper and dangerous operation. Verify proper operation after servicing.

## 5B-2. Testing the Transformer

**NOTE:** Keep the pump running.

Testing the transformer requires an AC voltmeter with a 50 volt (V) range. Test the transformer using the following procedures:

1. Clip a lead from the voltmeter to the yellow wire terminal on the transformer (this lead stays connected to this terminal for all tests).
2. Touch the other lead to the red wire terminal (see Figure 35). The voltmeter should read 20 to 28VAC.
3. If the voltmeter does not show voltage, check the electrical power supply.
4. If the voltage is less than 20VAC, the electrical circuit to the heater may be supplying less than 103VAC. This could be due to high pump load or air conditioners or other appliances on the circuit.

## 5B-3. Testing the Electrical Power Supply

The electrical components of the VW and PW heaters operate with supply voltage ranging from 103

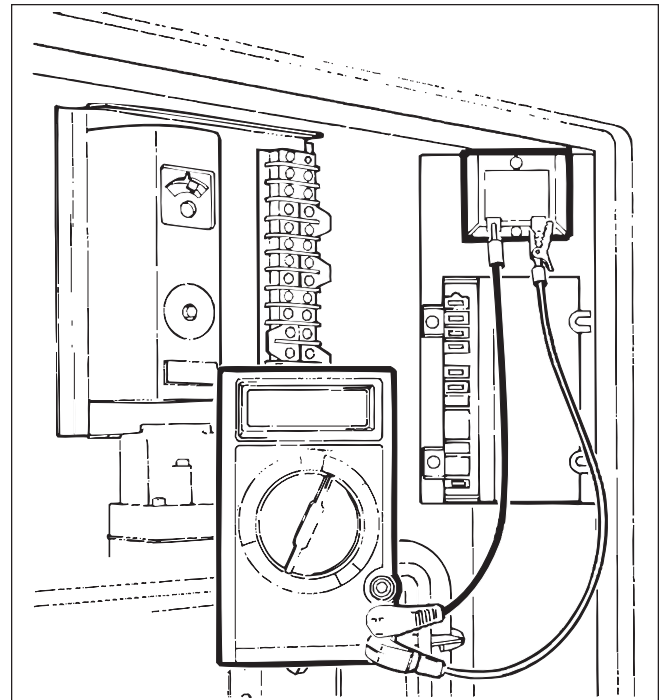

Figure 35. Testing the transformer.

to 126VAC at 60 Hertz (Hz). To test the electrical power supply:

1. Measure the voltage at the hot and neutral connections inside the heater electrical junction box.
2. Voltage outside of the required range may be due to poor wiring connections, to other loads (e.g., air conditioners, compressors) on the circuit, to high pump load, or to an electrical utility company problem.

## 5B-4. Testing the Manual Reset Hi-Limit Switch

To test the manual reset hi-limit switch (see Figure 36):

1. Touch the other lead of the voltmeter to both terminals of the manual reset hi-limit switch. The voltmeter should read 20 to 28VAC at both terminals.
2. If no voltage is detected at one terminal, reset the manual reset hi-limit switch by pressing the reset button. Check the temperature setting.
3. If after pressing the reset button there is still no voltage indicated at one terminal, replace the manual reset hi-limit switch. An open switch may indicate excessive water temperatures or improper setting.

## 5B-5. Testing the Flow Switch

The flow switch is a safety device that senses water flow through the heater. When the switch senses adequate water flow, it closes, allowing the heater to

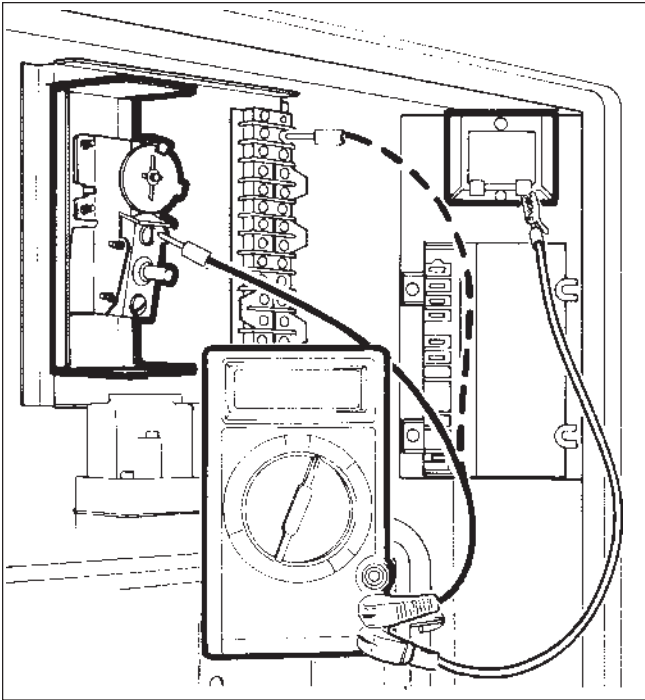

Figure 36. Testing the manual reset hi-limit switch.

fire. If the water flow is too low, the switch remains open and prevents the heater from firing regardless of the temperature control setting.

The flow switch is factory mounted and wired. Never attempt to repair the flow switch. If the flow switch is found to be defective, replace the flow switch. To test the flow switch:

1. Remove cap from flow switch.
2. Touch a voltmeter lead to each terminal of the flow switch.
3. If the voltmeter reads voltage at each of the terminals, the switch is good.
4. If there is no voltage at one terminal, it indicates an open switch. Replace the flow switch.

### 5B-6. Testing the Fusible Link (flame roll-out switch)

The fusible link is a thermally fusible element which shuts down the heater if it detects excessive temperatures inside the heater flue collector compartment. To test the fusible link (flame roll-out switch, if installed):

1. Remove the electrical wiring from the fuses and check across each fuse's terminals with a continuity or ohm meter.
2. Touch the voltmeter lead to the lower terminal on the terminal block (see Figure 37).
3. If the voltmeter reads voltage, the safety fuse and the fusible link are good.
4. Replace the fuse when an open circuit is detected. An open fuse indicates overheating in the flue collector or compartment.

5. Check for leaks of the flue collector, vent pipe, gaskets, and all connections.
6. Check the flue pipe for blockage.

### 5B-7. Testing the Fuse

To test the fuse:

1. Clip a lead of the voltmeter to the grounding terminal.
2. Touch the other voltmeter lead to the 24VAC terminal on the ignition control.
3. If there is no voltage, replace the fuse. A blown fuse is usually an indication of a short in the 24VAC circuit. It is important that the cause of the short be found and repaired. Do not jumper or bypass the fuse.

### 5B-8. Testing the Ignition Control (for spark ignition)

#### ⚠ Caution

The ignition control and igniter operate on 120V power. Keep this in mind while servicing the heater, and take care to avoid electrical shock.

The ignition control provides power to the igniter, opens the gas valve when there is a call for heat, and senses when a flame is established. To test the ignition control for spark ignition:

1. Clip one lead from the voltmeter to the yellow wire terminal on the transformer.

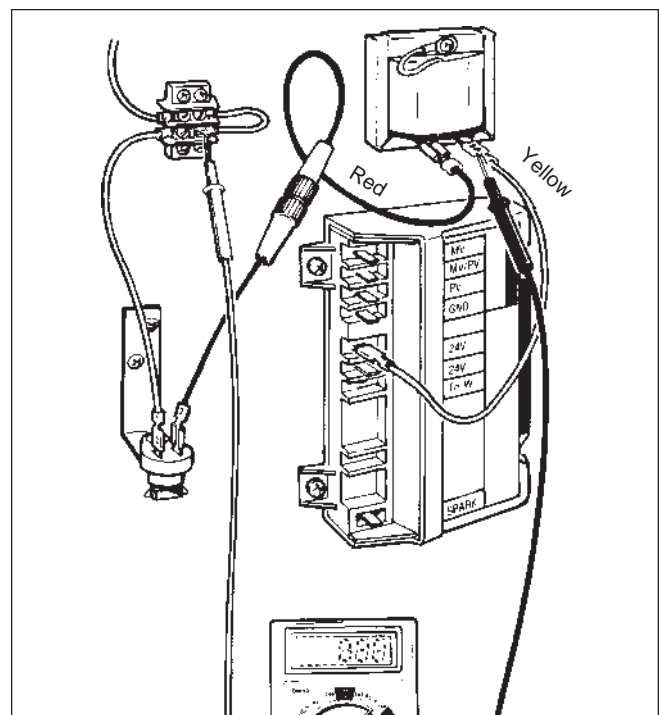

Figure 37. Testing the fusible link.

2. Touch the other voltmeter lead to the red 24V terminal on the ignition control.
3. If the voltmeter reads voltage, the temperature control and the manual reset hi-limit switch are not keeping the heater from firing.
4. Make sure the pilot burner is positioned next to the main burner (see Figure 38) and there is no soot or dirt on it.
5. Make sure the electrode (part of pilot assembly) is clean, the terminal connection is tight, and the stainless steel lead is at least 3/8 inch (9.5 mm) from the heater chassis and other metal parts.
6. Check for proper spark gap.

### 5B-9. Testing the Ignition Control (for standing pilot)

This test will determine if the ignition control is operating correctly. To test the ignition control for standing pilot:

1. Clip one lead from the voltmeter to the yellow wire terminal on the transformer.
2. Touch the other voltmeter lead to the terminal on the gas valve, where the brown wire is attached.
3. If the voltmeter reads voltage, the temperature control and the manual reset hi-limit switch are not keeping the heater from firing.
4. Make sure the pilot burner is positioned next to the main burner (see Figure 39) and there is no soot or dirt on it.
5. Make sure the electrode (part of pilot assembly) is clean, the terminal connection is tight, and the stainless steel lead is at least 3/8 inch (9.5 mm) from the heater chassis and other metal parts.
6. Check for proper spark gap.

### 5B-10. Testing the High Voltage Ignition Lead

Connections must be tight, and silicone rubber boots in place. Bare metal parts at the base of the manifold bracket must be at least 3/8 inch (9.5 mm) from other metal objects. To test the ignition lead:

1. Turn the control panel switch to on.
2. Make sure the temperature control is turned far enough to call for heat. There will be a loud clicking noise indicating the pilot electrode is sparking.
3. If no sparking is heard, pull the ignition lead from the ignition control and hold the bare terminal 1/8 to 3/16 inch (3.2 to 4.8 mm) from the ignition stud with a pair of insulated pliers (see Figure 40).

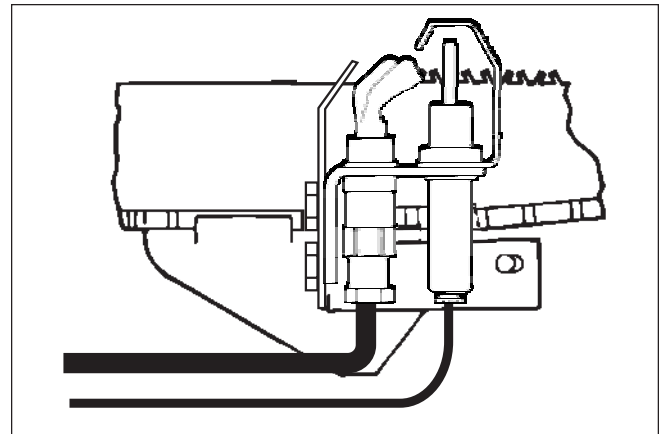

Figure 38. Pilot location (spark ignition).

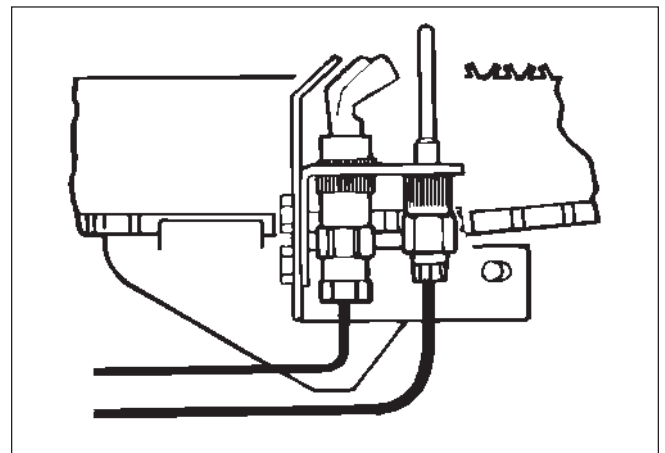

Figure 39. Pilot location (standing pilot).

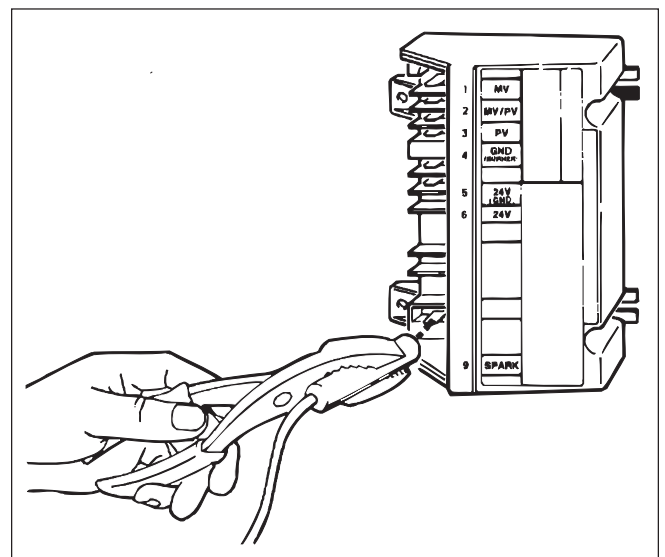

Figure 40. High voltage ignition test.

4. If a spark does not jump the gap, replace the ignition control.

**NOTE:** The ignition control cannot be repaired in the field. If it does not operate properly, replace it.

### 5B-11. Testing the Safety Shutoff (for standing pilot)

After lighting the heater, test the ignition system safety shutoff.

1. With the main burners firing, turn the gas valve control knob off.
2. Turn power to the heater off.
3. Set the temperature control to its lowest setting.
4. Wait 5 minutes.



**Flame Hazard.** Failure to wait 5 minutes, or not turning the gas valve knob to OFF, may cause the flow of unlighted main burner gas.

5. Turn the gas valve control knob to the PILOT position.
6. Without pressing the control knob down, it should be impossible to light the pilot.
7. Relight the pilot following the lighting instructions found on the inside of the heater.
8. Reset the temperature control.
9. Light the heater following the instructions found on the inside of the heater.

### 5B-12. Testing the Safety Shutoff (for automatic pilot)

1. Find the red silicone rubber insulated wire that runs from the pilot to the ignition stud on the ignition control module.
2. With the main burners firing, use an insulated pair of pliers to disconnect the sensor wire from the control module. Do not pull on the wire. The main burner flame should immediately go out.
3. Turn the gas valve control knob to the off position.
4. Reattach the red silicone wire to the control module.

### 5B-13. Testing the Igniter Electrode

To test the igniter electrode:

1. Make sure all of the wire connections on the ignition control and the gas valve are tight.
2. Make sure the wiring agrees with the wiring diagrams found on the inside of the heater.
3. Check for sparking at the igniter electrode.
4. If there is sparking at the igniter electrode, but there is no pilot ignition after 2 or 3 minutes, clip a lead from the voltmeter between the yellow wire terminal on the transformer and the brown wire terminal on the gas valve.
5. If the voltmeter does not show voltage, replace the ignition control.

6. If the voltmeter reads 20 to 28VAC, but there is no pilot ignition, check for
  - a: air in gas lines.
  - b: restrictions in gas line, valve or pilot tubing.
  - c: clogged pilot orifice.
 If these are correct then replace gas valve (see Section 4C).

### WARNING

Never attempt to repair the gas valve. Such attempts will void the warranty, and could lead to dangerous results.

### 5B-14. Testing the Pilot Thermocouple (for standing pilot)

If there is voltage to the gas valve, the pilot is lit, the thermocouple is properly positioned, the temperature control is set high enough to call for heat; then the gas valve or the pilot thermocouple may be the problem. To test the pilot thermocouple:

1. Remove the pilot thermocouple fitting from the gas valve.
2. Clip one lead of a millivolt meter on the center post of the tube and the other lead on the copper pilot thermocouple shield.
3. If the millivolt meter reads about 30 millivolts, go to step 5.
4. If the millivolt meter does not show voltage or voltage is very low, it could indicate a dirty or clogged pilot. Clean and recheck the pilot thermocouple. If voltage still does not show or is very low, replace the pilot thermocouple.
5. To test the pilot thermocouple under load, screw the pilot thermocouple into the end of a millivolt reading adapter (see Figure 41).
6. Clip one lead of a millivolt meter to either side of the millivolt adapter and clip the other lead to ground.
7. Light the pilot following the instructions found on the inside of the heater.
8. Set the temperature control high enough to call for heat.
9. With the heater firing, take a millivolt reading.
10. If the millivolt meter does not read about 15 millivolts, replace the pilot thermocouple.

### 5B-15. Testing for Pilot Burner (for spark ignition)

When the pilot burner lights, the sparking should stop and the main burners should fire. If the sparking continues and the main burners do not fire:

1. Check all wire connections, ignition cable, and using a mirror, make sure there is a pilot flame.

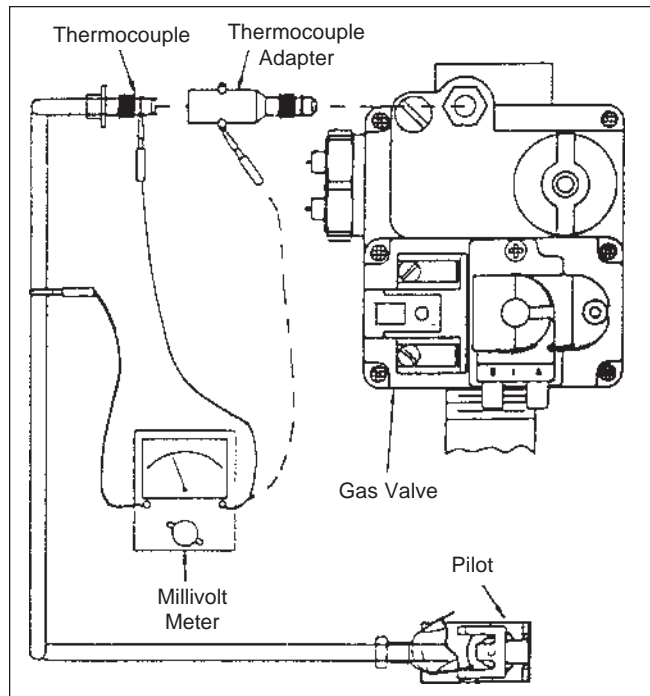

Figure 41. Testing the pilot thermocouple.

2. If everything appears all right, measure flame sensing current by connecting a direct current (DC) microamp meter between terminal No. 12 and the GND (BURNER) terminal on the ignition control (see Figure 42).

**NOTE:** Separate the microamp meter leads from each other and clear the heater chassis for most of their length to properly perform this test.

3. When the pilot lights, the microamp meter should read 1.5 microamps or more with or without the main burners firing. A smaller current could be caused by poor pilot flame, the position of the pilot electrode, or bad cable and connectors.
4. If the pilot flame and sensor electrode are all right, but there is no main burner ignition, clip one lead from a volt meter between the yellow wire terminal on the transformer and the brown wire terminal on the gas valve.
5. If the voltmeter reads between 20 to 28VAC, but the main burners do not fire, replace the gas valve (see Section 4B).

#### 5B-16. Testing for Burner Ignition (for standing pilot)

If the pilot flame and pilot thermocouple generator are all right, but there is no main burner ignition:

1. Clip one lead of a volt meter between the yellow wire on the transformer and the brown wire terminal on the gas valve.
2. If the volt meter reads between 20 to 28VAC, but the main burners do not fire, replace the gas valve (see Section 4B).

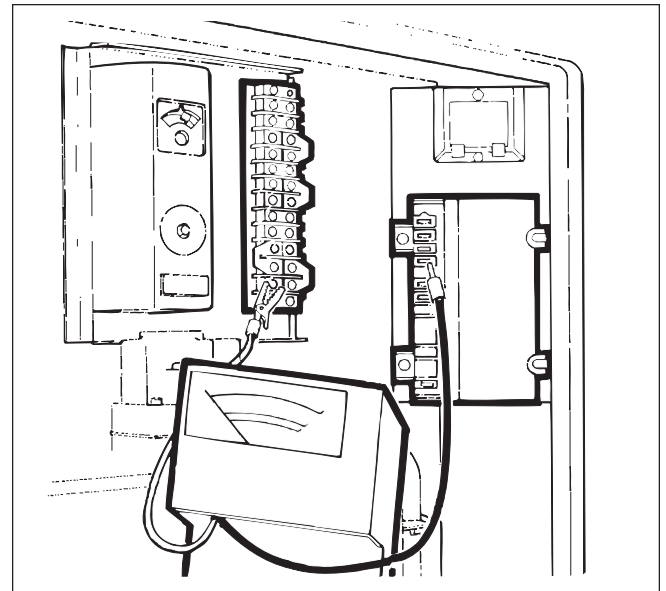

Figure 42. Flame sensing current.

#### 5B-17. Heater Will Not Shut Off

1. If the heater stays on with the brown wire on the gas valve disconnected, replace the gas valve (see Section 4B).

#### **WARNING**

Never attempt to repair the gas valve. Such attempts will void the warranty, and could lead to dangerous results.

2. Check electrical components for loose wires. Disconnect one of the lead wires on the gas valve. If the heater goes off, the wiring could be at fault. Repair or replace as necessary.

#### 5B-18. On-Off Main Burner Cycling

The main burners cycling on and off can be caused by:

1. Poor wind conditions on an outdoor installation.
2. Pilot components out of position.
3. Low gas pressure causing an improper pilot flame.

The pilot flame may appear to be all right until the main burners come on, then the pilot flame shrinks. An undersized gas supply line may cause this.

#### 5B-19. Testing the Terminal Strip/External Controls

The terminal strip has been included so the heater can be operated by various external controls not provided by Laars. Determine whether or not an external control is open by checking for voltage at each terminal. If there is voltage at one terminal and not the other, examine the external control. It may require service or replacement.

## SECTION 6. Parts List for VW and PW Heaters

### 6A. General Information

To order or purchase parts for the Laars VW-PW Volume Water Heaters, contact your nearest Laars wholesaler. If they cannot supply you with what you need, contact Customer Service, Laars (see back cover for address, telephone and fax information).

### 6B. Parts List

Item	Description	Part Number
<b>PILOT GAS SYSTEM</b>		
1.	Burner, Pilot Only, Standing Pilot, Nat. ....	W0036300
	Standing Pilot, LP .....	W0036400
2.	Pilot Thermocouple Only (not shown) ....	W0036500
3.	Pilot Burner Electrode Assy., Nat. ....	W0030600
	Electrode Assy., LP .....	W0039600
4.	Pilot Bracket Shield .....	10461100
5.	Ceramic Insulator Assy. (not shown) .....	10418805
<b>MAIN GAS SYSTEM</b>		
6.	Burner Tray Assembly Nat. IID, On/Off .....	10571802-05
	Nat. IID, Mech. Mod. ....	10572102-05
	Nat. IID, 2-Stage .....	10581802-05
	Nat. Standing Pilot, On/Off .....	10571602-05
	Nat. Standing Pilot, Mech. Mod. ....	10571902-05
	LP IID, On/Off .....	10737502-05
	LP IID, Mech. Mod. ....	10737402-05
	LP IID, 2-Stage .....	10737302-05
	LP Standing Pilot, On/Off .....	10571702-05
	LP Standing Pilot, Mech. Mod. ....	10572002-05
7.	Gas Valve Nat. IID .....	V0073500
	Nat. Stdg Pilot, (Model 175) .....	V0058900
	Nat. Stdg Pilot, (Model 250) .....	V0073300
	Nat. Stdg Pilot, (Model 325-400) .....	V0049900
	LP IID, O/O,MM (Models 175 thru 400) ..	V0073600
	LP IID, 2-Stage (Models 175 thru 250) ...	V0073100
	LP IID, 2-Stage (Models 325 and 400) ...	V0073200
	LP Stdg Plt, .....	V0073700
8.	Burner, Main .....	L0052300
9.	Burner, Main w/Pilot Bracket .....	10457500
10.	Orifice, Main Burner, Nat. ....	L0032200
	Orifice, Main Burner, LP .....	L0032900
11.	Burner Tray Weldment .....	R0099502-05
<b>ELECTRICAL SYSTEM</b>		
12.	High Tension Lead .....	10449513
13.	Ignition Control .....	E0094001
14.	Transformer, 115V/24V, 40VA .....	E0086100
15.	Fuse Holder w/2 Amp Fuse .....	10690300
16.	Fuse, 2 Amp .....	E0084400
17.	Switch, Flow, Outdoor .....	E0013000
18.	Fusible Link (175 thru 250) .....	E0099403
19.	Switch, Toggle, On/Off .....	E0077000
20.	Switch, Hi-Limit, Manual Reset .....	E0015900

Item	Description	Part Number
21.	Temp Controller, Auto. Reset .....	E0014400
	(Model 250) .....	E0141302
24.	Switch, Drafthood .....	E0121000
<b>VENT SYSTEM</b>		
26.	Vent Cap .....	R0318602-05
27.	Drafthood .....	R0318702-05
28.	Drafthood/Vent Cap Adapter Plate .....	10535302-05
29.	Flue Transition Ring .....	10515502-05
30.	Top Assembly .....	10568006-10
31.	Flue Collector Assembly .....	10564802-05
32.	Top Filler Plate .....	10535202-05
33.	Clip, Baffle Retainer .....	S0083900
34.	Baffle, Heat Exchanger (8) .....	10697402-05
<b>FIREBOX COMPONENTS</b>		
35.	Tile, Side .....	T0021400
36.	Tile, Front .....	T0021502-05
37.	Tile, Rear .....	T0021602-05
38.	Tile Cover, Side .....	10167300
39.	Tile Cover, Front and Rear .....	10314902-05
40.	Insulation, Jacket .....	10458902-05
<b>WATER SYSTEM</b>		
41.	Bracket, Heat Exchanger .....	10457000
42.	Heat Exchanger, Tube Assy. Copper (Thickwall) .....	R0095502-05
	Cupronickel (Thickwall) .....	R0095602-05
43.	Plug, 1/4 11nch NPT .....	P0026800
44.	In/Out Header Cast Iron (S0079100), 2-Pass .....	10593700
	Bronze (S0081700), 4-Pass .....	10546900
45.	Return Header Cast Iron (S0079200), 2-Pass .....	10593800
	Bronze (S0075900), 4-Pass .....	10546800
46.	Header Gasket (18) .....	R0050800
47.	Bolt, Dome Head (8) .....	F0046100
48.	Bolt, Flat Head, Square Neck, 3/8 Inch, 16 x 2-3/4 Inch .....	F0041000
49.	Screw, Hex Cap .....	F0031700
50.	Gasket Cast Iron Flange .....	S0076500
	Bronze Flange .....	S0028000
	Bronze Flange .....	S0053100
51.	Nut .....	F0040800
52.	Washer .....	F0011100
<b>WATER SYSTEM - Cont'd</b>		
53.	Flange, 1-1/2 in. Cast Iron (S0076400) .....	10573600
	Bronze (S0071800) .....	10489400
54.	Pressure Relief Valve (125 psi) .....	A0001200
55.	Pump and Rainshield Assembly Model 175 .....	10565604-07
	Models 175 thru 400 .....	10565603
	Model 250 .....	10565605
	Models 325 and 400 .....	10565606
56.	Valve, Drain .....	P0058700
57.	Well, Temp Contrl, 1/4 Inch NPT .....	E0025900
58.	Nipple, Brass, 3/4 Inch .....	P0025300
59.	Nipple Bronze .....	P0075700
	Cast Iron .....	P0024400

Item	Description	Part Number
60.	Tee	
	Bronze .....	P0075600
	Cast Iron .....	P0071700
61.	Bushing, Brass .....	P0018500
62.	Bracket, Holddown .....	10726300
63.	Clamp, Holddown .....	10726200

Item	Description	Part Number
<b>JACKET COMPONENTS</b>		
64.	Jacket Assembly .....	10568302-05
65.	Door .....	10448902-05
66.	Deflector, Rear .....	10563706-10
67.	Deflector, Lower .....	10563606-10
68.	Gap Closure, In/Out .....	10448202
69.	Gap Closure, Return .....	10448302

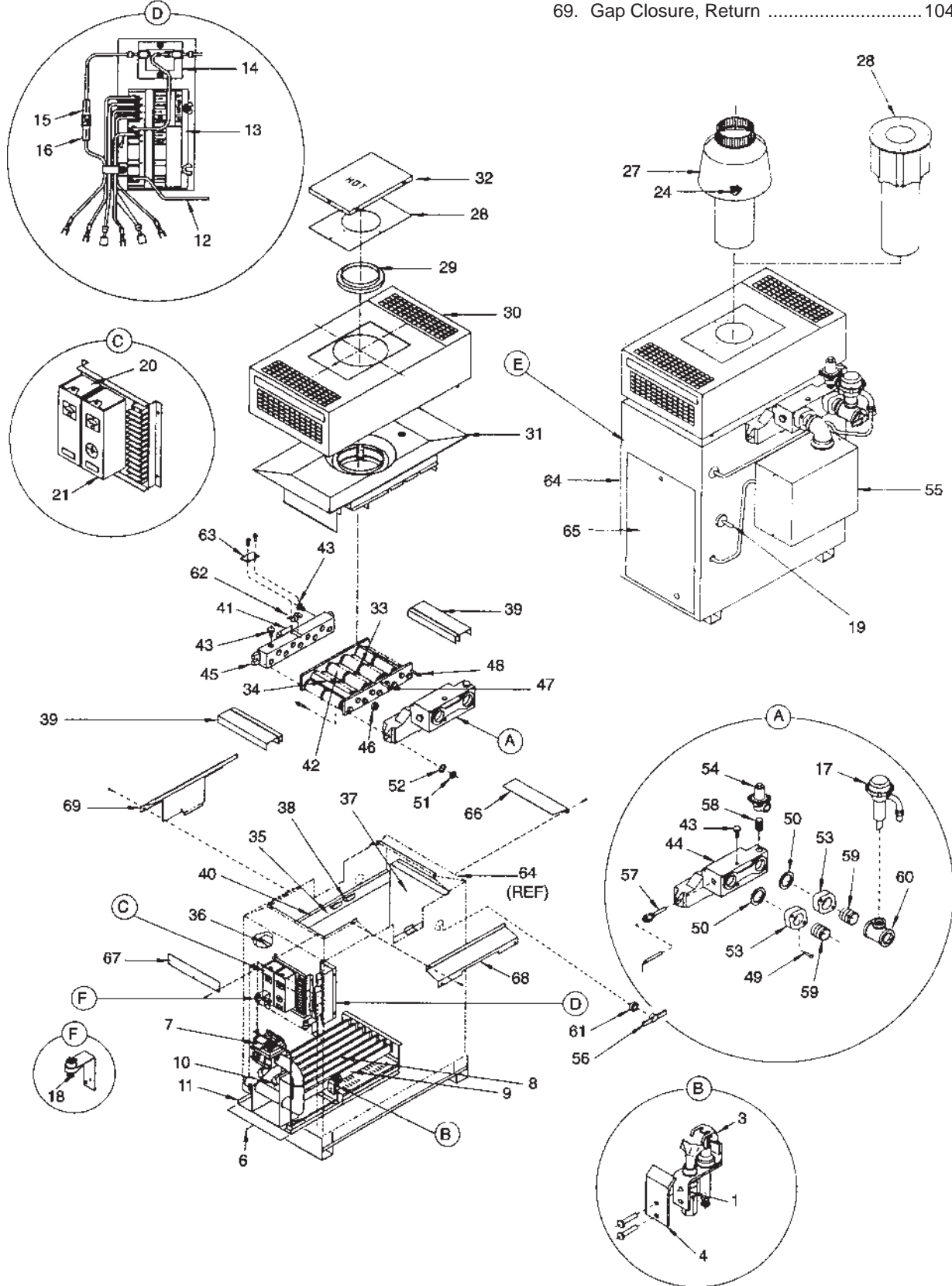



H0147500C



Waterpik Technologies, Inc.  
6000 Condor Drive, Moorpark, CA 93021 • 805.529.2000 • FAX 805.529.5934  
20 Industrial Way, Rochester, NH 03867 • 603.335.6300 • FAX 603.335.3355  
480 S. Service Road West, Oakville, Ontario, Canada L6K 2H4 • 905.844.8233 • FAX 905.844.2635  
[www.laars.com](http://www.laars.com)

Litho in U.S.A. © Laars Heating Systems 0006 Document 2051C